

1st 1/4 Deeper run  
PO # 2569 CG  
1982

SNAKE

Beige Paint  
S-26058  
RC dk. Blue  
Ditzler 4343

# Dixie-Narco<sup>®</sup> INC.

Lawrence Street (304) 725-3481  
Ranson, West Virginia 25438 (800) 624-0553

New CC Coin Insert  
SN 2990  
Exception 2992

New CC Throttle Stud, Spring re dip.  
801-503-040.11

## SERVICE MANUAL AND PARTS LIST

- 0001-2569 CG
- 1300-2633 CH
- 0001-2679 DH
- 0001-2768 DI

4/1188 Red Paint  
P. H. H. S 26970

PL Black paint  
P. H. H. S 26952

Touch up white  
PPG-523519 acrylic

refurbish paint  
acrylic enamel

Top Green  
S 26022

## Bottle/Double Depth Can Venders

# 1 1/4" Deeper

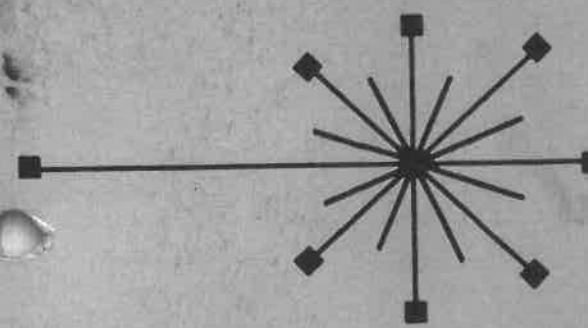

## ADAPTABLE MODELS

WITH RED CAM ON VEND MOTORS  
WITH SINGLE RELAY LOCK-OUT CIRCUIT

## Dual Red Cam Adaptables

- DNCB 168/99-5
- DNCB 168/99-6
- DNCB 240/138-5
- DNCB 240/138-6
- DNCB 276/162-5
- DNCB 276/162-6
- DNCB 330/189-5
- DNCB 330/189-6
- DNCB 320/184-7
- DNCB 320/184-8
- DNCB 368/216-7
- DNCB 368/216-8
- DNCB 440/252-7
- DNCB 440/252-8
- DNCB 304/174-9
- DNCB 304/174-10
- DNCB 348/206-9
- DNCB 348/206-10
- DNCB 414/239-9
- DNCB 414/239-10

cluster sw  
4.10

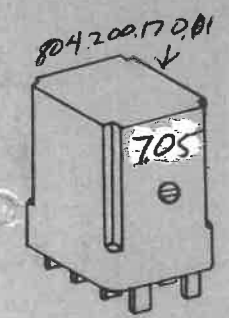

804 200.170.01



Brown  
S 27043

## Red Cam Adaptables

- DNCB 180/105-5
- DNCB 360/210-5
- DNCB 360/210-6
- DNCB 432/246-5
- DNCB 432/246-6

Includes Magnum Models  
Includes Century II Models

MC models  
37 inch wide 1985  
26 " "

COKE C 1987



The number 0001-2569CG on the front cover of the manual is the beginning Serial Number for the DNCB 6 and 8 column models listed on the front cover.

However: In production run. . .2565 the following serial numbers were 1¼" Deeper Models.  
1389-2565, 1391-2565, 1393-2565 thru 1417-2565, 1419-2565 thru 1434-2565,  
1436-2565 thru 1438-2565, 1436-2565 thru 1438-2565, 1440-2565 thru 1490-  
2565, 1494-2565, 1498-2565, and 1499-2565

In production run. . .2566 the following serial numbers were 1¼" Deeper Models.  
0001-2566 thru 0084-2566, 0087-2566, 0090-2566 thru 0093-2566, 0096-2566,  
0098-2566, 0105-2566, 0108-2566, 0131-2566, 0147-2566, 0152-2566, 0206-2566,  
0329-2566, 0380-2566, 0750-2566

The number 1300-2633CH on the front cover of the manual is the beginning Serial Number for the DNCB 9 and 10 column models listed on the front cover.

The number 0001-2679DH on the front cover of the manual is the beginning Serial Number for the Magnum models listed on the front cover.

The number 0001-2768DI on the front cover of the manual is the beginning S/N for the Century II models listed on the front cover.

The letter C indicates the quarter of the calendar year in which the vender was manufactured.

The letter H indicates the calendar year in which the vender was manufactured.

Thus C = 3rd quarter

H = Year 1983

The date system started in 1976

Thus,

For a given year the first letter is the quarter, i.e.,

A = First Quarter *Jan Feb Mar*

B = Second Quarter *Apr May Jun*

C = Third Quarter *July Aug Spt*

D = Fourth Quarter *Oct Nov Dec*

The second letter is the year, i.e.,

A = Year, 1976

B = Year, 1977

C = Year, 1978

D = Year, 1979

E = Year, 1980

F = Year, 1981

G = Year, 1982

H = Year, 1983

I = Year, 1984

J = Year, 1985

K = Year, 1986

L = Year, 1987

M = Year, 1988

*rotor  
&  
oscillators  
mounted  
around  
14 3/8" For 1 1/2" deeper  
exhibit*



## - WARRANTY -

Dixie-Narco Warrants to the original purchaser of a Dixie-Narco unit all parts thereof (except light bulbs, fuses, or finish) to be free from defects in material and workmanship, under normal use and service for a period of 15 months from the date of shipment of the unit from either our plant or warehouse.

All conditions as set forth in this Warranty apply also to the Ardac Dollar Bill Validator except that the Ardac Dollar Bill Validator is warranted for 12 months from the date of shipment of the Ardac Validator from either our plant or warehouse.

The term "original purchaser" as used in this warranty shall be deemed to mean that person, firm, association, or corporation to which the machine was sold originally.

Dixie-Narco's obligation under this warranty is limited to repairing or replacing without charge any part which upon our examination and to our satisfaction was defective in material or in workmanship and which failed under normal operating conditions and service.

The hermetically sealed refrigeration system, consisting of the motor compressor, condenser, evaporator and the refrigerant tubing is warranted for a total period of five (5) years and three (3) months from date of shipment.

The vend motor is warranted for a total period of five (5) years and three (3) months from date of shipment.

The five year warranty does not apply to any electrical controls, fan motors, overload switches, starting relays, temperature controls, wiring harnesses, cabinet or finish. Dixie-Narco's obligation under this warranty on the sealed refrigeration system referred to above is limited to repairing and returning or replacing at Dixie-Narco's option any unit with a similar unit when upon examination and to our satisfaction it was determined to have been defective. If our examination reveals that the unit is inoperative because of a defective accessory, both cost of repairs and freight charges will be paid by the customer.

Dixie-Narco will pay transportation charges under this warranty on all parts replaced or repaired when transportation has been made in the most economical way. If special handling or special transportation is used or requested, the charges will be paid by the customer.

This warranty only applies to units located within the United States and when operated in normal conditions and with electrical power supplies of 110/120 volts, 60 cycle. Further, the warranty is voided when a unit or any part has been subject to misuse, neglect, alteration without proper authorization, accident, or damage caused by transportation, flood, civil disorder, fire or the Acts of God.

"Return Material Tags", indicating model number of unit, serial number, and explanation of defect, must accompany all returned parts or units. In addition, for Ardac components the serial number of the component that failed is needed. "Return Material Tags" will be furnished upon request.

DIXIE-NARCO

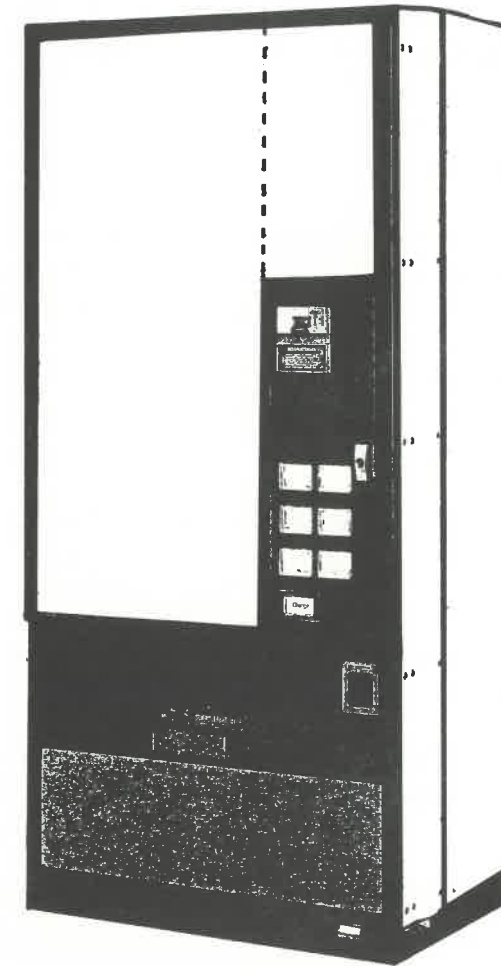

DNCB 180/105-5  
 Height: 56-11/16  
 Width: 28-5/16  
 Depth: 26  
 Shipping Wt. 462 lbs.  
 Capacity:  
 Can 180  
 Bottle, Reg. 105  
 10 oz. PLB

DNCB 168/99-5-6  
 Height: 56-11/16  
 Width: 28-5/16  
 Depth: 26  
 Shipping Wt. 462 lbs.  
 Capacity:  
 Can, 12 oz. 168  
 Bottle, Reg. 99  
 10 oz. PLB 168

DNCB 240/138-5-6  
 Height: 66-5/16  
 Width: 28-5/16  
 Depth: 26  
 Shipping Wt. 530 lbs.  
 Capacity:  
 Can, 12 oz. 240  
 Bottle, Reg. 138  
 10 oz. PLB 228

DNCB 276/162-5-6  
 Height: 72  
 Width: 28-5/16  
 Depth: 26  
 Shipping Wt. 573 lbs.  
 Capacity:  
 Can, 12 oz. 276  
 Bottle, Reg. 162  
 10 oz. PLB 264

DNCB 360/210-5-6  
 Height: 72  
 Width: 37-1/16  
 Depth: 26  
 Shipping Wt. 670 lbs.  
 Capacity:  
 Can, 12 oz. 360  
 Bottle, Reg. 210  
 10 oz. PLB 348

DNCB 432/246-5-6  
 Height: 79½  
 Width: 37-1/16  
 Depth: 26  
 Shipping Wt. 716 lbs.  
 Capacity:  
 Can, 12 oz. 432  
 Bottle, Reg. 246  
 10 oz. PLB 432

DNCB 320/184-7-8  
 Height: 66-5/16  
 Width: 37-1/16  
 Depth: 26  
 Shipping Wt. 643 lbs.  
 Capacity:  
 Can, 12 oz. 320  
 Bottle, Reg. 184  
 10 oz. PLB 304

DNCB 368/216-7-8 ← 489  
 Height: 72  
 Width: 37-1/16  
 Depth: 26  
 Shipping Wt. 690 lbs.  
 Capacity:  
 Can, 12 oz. 368  
 Bottle, Reg. 216  
 10 oz. PLB 352

DNCB 440/252-7-8 ← 588  
 Height: 79½  
 Width: 37-1/16  
 Depth: 26  
 Shipping Wt. 748 lbs.  
 Capacity:  
 Can, 12 oz. 440  
 Bottle, Reg. 252  
 10 oz. PLB 432

DNCB 348/206-9-10  
 Height: 72  
 Width: 37-1/16  
 Depth: 26  
 Shipping Wt. 690 lbs.  
 Capacity:  
 Can, 12 oz. 348  
 Bottle, Reg. 206  
 10 oz. PLB 328

DNCB 414/239-9-10  
 Height: 79½  
 Width: 37-1/16  
 Depth: 26  
 Shipping Wt. 748 lbs.  
 Capacity:  
 Can, 12 oz. 414  
 Bottle, Reg. 239  
 10 oz. PLB 396

DNCB 304/174-9-10  
 Height: 66-5/16  
 Width: 37-1/16  
 Depth: 26  
 Shipping Wt. 643 lbs.  
 Capacity:  
 Can, 12 oz. 304  
 Bottle, Reg. 174  
 10 oz. PLB 284

**CONTENTS**

**WHAT TO DO WHEN YOU GET A NEW VENDER**  
SET IT UP . . . . . 4  
LOAD THE VENDER . . . . . 5  
CHECK IT OUT . . . . . 6  
PUT IT TO WORK . . . . . 7

**HOW THE VENDING MECHANISM WORKS**  
ELECTRICAL PARTS . . . . . 8  
STUDY — vending cycle and across the line wiring diagram . . . . . 14  
VEND CYCLE . . . . . 15

**HOW TO TAKE CARE OF THE VENDER**  
WHAT TO CLEAN . . . . . 17  
WHEN AND WHAT TO LUBRICATE . . . . . 17  
THINGS TO ADJUST . . . . . 18  
HOW TO CORRECT COMMON VENDING TROUBLES . . . . . 35

**HOW THE REFRIGERATION SYSTEM WORKS**  
MECHANICAL PARTS . . . . . 38  
ELECTRICAL PARTS . . . . . 39  
ELECTRICAL OPERATION . . . . . 42  
ELECTRICAL CIRCUITS AND CIRCUIT DIAGRAMS . . . . . 44  
REFRIGERATION CYCLE . . . . . 49

**HOW TO TAKE CARE OF THE REFRIGERATION SYSTEM**  
WHAT TO CLEAN . . . . . 50  
WHEN AND WHAT TO LUBRICATE . . . . . 50  
CORRECTING TROUBLES . . . . . 50  
HOW TO CORRECT COMMON REFRIGERATION TROUBLES . . . . . 51

**ACROSS THE LINE DIAGRAM . . . . . 62**

**WIRING DIAGRAM . . . . . 65**

**PARTS LIST . . . . . 74**

## DIXIE-NARCO

### WHAT TO DO WHEN YOU GET A NEW VENDER

#### – SET IT UP –

##### KEYS

Keys are taped inside the coin return cup.

##### SERIAL NUMBER PLATE

The serial number plate is attached outside to the left side of the main door.

##### COIN MECHANISM

The coin mechanism is shipped in a separate package.

To install, do this:

1. Open the inner door.
2. Remove the slug rejector.
3. Line the three holes in the coin mechanism with the three screws and push the coin mechanism over the three screws. Let the coin mechanism drop down onto the screws, tighten the screws.
4. Reinstall the slug rejector.
5. Connect the changer plug to the socket.

##### INSTALLATION OF PRICE CARD

1. Install card from rear of main door.

#### – LOAD THE VENDER –

##### ADJUSTMENTS

1. The Adaptables are shipped set to dispense cans.
2. For adjustments, look under "Things to Adjust".

##### LOAD THE VENDER

1. Read thoroughly, "Things To Adjust".
2. Adjust for dispensing cans or bottles.
3. Load the vender with eight (8) cans or bottles.
4. Install coin changer.
5. Plug vender "in" - Dispense cans or bottles to check vending operation.



WHAT TO DO WHEN YOU GET A NEW VENDER (Cont.)

– LOAD THE VENDER – (Cont.)

**OPERATIONAL CHECKS**

1. Plug service cord into outlet with correct voltage. (See serial number plate.) Do Not use extension cords with less than 16 guage wire.
2. The vender must be grounded. If 3 prong outlet is available, plug vender directly into outlet. If 3 prong outlet is not available, plug the vender into 2 prong outlet, using 2 prong adapter. Be sure to ground "pigtail" on adapter.
3. Make sure that nothing obstructs air intake at bottom of door. Check rear of cabinet occasionally to be sure that exhaust is not blocked by waste paper, etc.

**CARE AND MAINTENANCE**

1. Exterior cleaning. Wash cabinet periodically with soap and water. Wax often, using a good automotive wax.
2. If corrosion occurs on cabinet interior, rub it off with fine steel wool and paint over spot with aluminum paint, or zinc rich.
3. Keep condenser clean. Use brush or vacuum cleaner to remove dust accumulation from condenser.

**PROPER SELECTION**

Selections on the front door control panel are as in sketch below:

See stack numbering sequence on inside of vender.



WHAT TO DO WHEN YOU GET A NEW VENDER (Cont.)

– CHECK IT OUT –

WHAT TO DO	WHAT SHOULD HAPPEN	WHAT SHOULDN'T HAPPEN
<p>Plug the supply cord in, close the vender door.</p>	<p>The compressor runs. The condenser fan runs. The evaporator fan runs. "Correct change only" window lights.</p>	<p>The refrigerant lines rattle.</p>
<p>Put in correct change.</p>	<p>Push the select button to dispense a can or bottle.</p>	<p>Some cans or bottles are frozen or the next to be vended cans or bottles are above the temperature of 38°F.</p>
<p>Load the money tubes and put a quarter into the vender.</p>	<p>A can or bottle may be dispensed from the vend stack and correct change is returned.</p>	
<p>Fully load the vender with warm cans or bottles and let it run over night, then vend a can or bottle from each vend stack.</p>	<p>The first can or bottle vended has a temperature of 32° to 34° F.</p>	

– PUT IT TO WORK –

**SPACE NEEDED**

Size of the working space needed around the vender is shown on the title page of this manual. DO NOT block the rear of the vender. Keep the vender 4 inches from the wall to provide adequate ventilation for the condenser. Make sure that nothing obstructs air intake at the bottom of the door.

**WHAT TO DO WHEN YOU GET A NEW VENDER (Cont.)****— PUT IT TO WORK — (Cont.)****LEVEL THE VENDER**

Level the vender. When the vender is level then the door can be opened to any position and it will not move by itself. Try it half closed, straight open and wide open before you decide that the vender is level.

Make sure that all of the leveling screws are touching the floor.

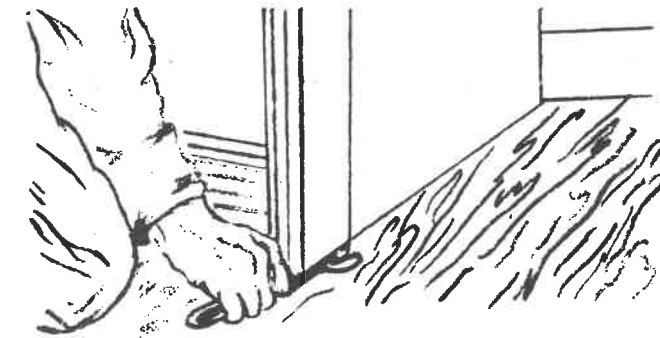
**Level The Vender****ELECTRIC POWER NEEDED**

Look at the serial number plate on the right side to find out what the vender's power needs are. Be sure that the vender gets the right power.

The vender uses 115 volts single phase, either 50 or 60 cycle, alternating current. The voltage must never be lower than 90 or above 125.

**GROUND THE VENDER**

This vender is made with a three prong plug on the supply cord. It grounds when the plug is put into a three prong outlet. If there is no prong outlet near the vender, use a two prong adapter. If a two prong adapter is used, make sure the adapter's ground wire is connected to a good ground.

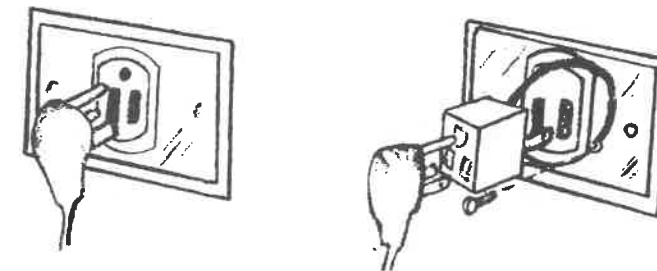
**Ground The Vender**

**HOW THE VENDING MECHANISM WORKS  
— ELECTRICAL PARTS —**

**CORRECT CHANGE LAMP**

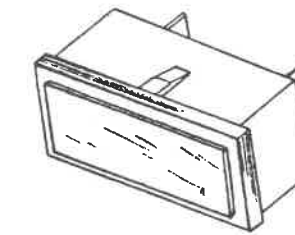

**Correct Change Lamp**

The correct change lamp is mounted in the coin insert casting and is retained by projections top and bottom.

The correct change lamp is in the coin tube switch circuit and is "ON" when coins are in the tube.

**SELECT SWITCH NO. 1, 2, 3, 4, 5, 6, 7 & 8**

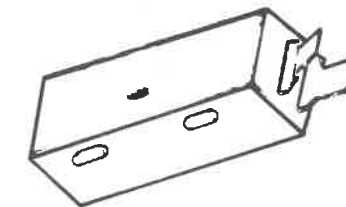

**Select Switch**

The select switch is located in the selector panel behind the push button and is secured with two (2) screws.

The N.O. contact of the Select Switch is in the Vend Motor Coil and the Sold Out Lamp circuits. This N.O. contact closes and completes the Vend Motor Coil Circuit and the Sold Out Lamp Circuit.

The N.C. contact of the Select Switch is in the Vend Motor Coil Circuits. This N.C. contact opens in the Select Panel Circuit.

**LAMP SOLD OUT SWITCH 1, 2, 3, 4, 5 & 6**

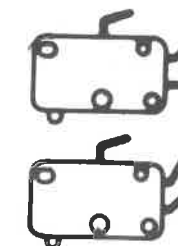

**Lamp Sold Out Switch**

The lamp sold out switch (one for each vending circuit) is located near the bottom of the column at the front and is fastened with screws.

The N.C. contact of the (lamp) sold out switch is in the Vend Relay Coil Circuit and the Coin Changer Magnet Circuit. This N.C. contact (kept closed by can or bottle) is in parallel with all of the other N.C. contacts of the Lamp Sold Out Switches and when all are open, the coin changer magnets are turned off and the changer will not accept coins.

The N.O. contact of the (Lamp) sold out switch is in the sold out lamp circuit (kept open by can or bottle). When not kept open by can or bottle, this N.O. contact closes and completes the sold out lamp circuit.

## HOW THE VENDING MECHANISM WORKS (Cont.)

## - ELECTRICAL PARTS - (Cont.)-

## SOLD OUT LAMPS

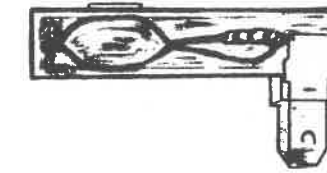

Sold Out Lamp

The sold out lamp (one for each vending circuit) is secured to the back of the select button in the Selector Panel.

The sold out lamp is turned on by the closing of the N.O. contacts of the lamp sold out switch.

## COIN VEND SWITCH (Coin Changer)

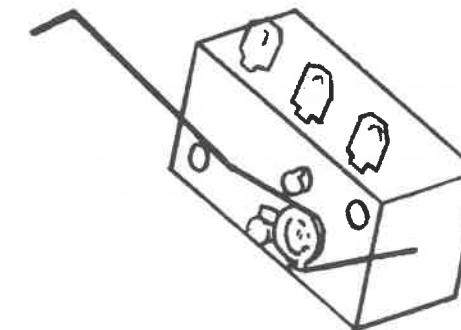

Coin Vend Switch

The coin vend switch is located below the slug rejector and is fastened to the coin changer housing with two (2) screws and nuts.

The N.O. contact of the coin vend switch is in the vend relay coil and the coin changer magnet circuits. This N.O. contact closes and completes the vend relay coil circuits.

The N.C. contact of the coin vend switch is in the vend motor coil circuits. This N.C. contact closes in the vend motor coil circuits to set up these circuits so that a selection can be made.

HOW THE VENDING MECHANISM WORKS (Cont.)

— ELECTRICAL PARTS — (Cont.)

VEND SOLD OUT SWITCH 1, 2, 3, 4, 5, 6, 7 & 8



Sold Out Switch

The vend sold out switch (one for each vending circuit) is located on a bracket at the base of each vend stack.

The N.C. contact of the vend sold out switch is in the Vend Motor Circuit. This N.C. contact (held closed by can or bottle) stays closed in the vend motor circuit so the Vend Motor Circuit can be completed.

HOW THE VENDING MECHANISM WORKS (Cont.)

ELECTRICAL PARTS (Cont.)

VEND MOTOR

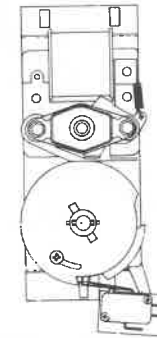

For Narrow Column

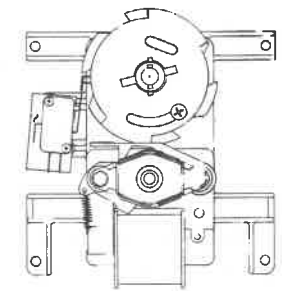

For Standard Column

VEND MOTOR

The vend motor (one for each vending stack) is mounted on a bracket at the front of the vender.

The vend motor is in the vend motor coil circuit. The vend motor runs when a N.O. select switch (pushed) closes and completes the vend motor circuit. The vend motor continues to run through the N.C. contact (worked by the vend motor cam) of the cam hold switch. The vend motor stops when the vend motor switch arm drops off of the high side of the vend motor cam.

MAGNETS (Coin Changer)

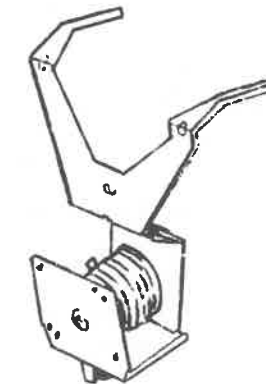

Coin Return Magnet

The magnets are in the coin changer behind the coin rejector.

The magnets N.O. and N.C. are in the Vend Realy Coil Circuit. The coin changer magnet are turned off when the N.C. Vend Relay Switch No.1 opens and breaks the coin changer magnet circuit.

**HOW THE VENDING MECHANISM WORKS (Cont.)**

**ELECTRICAL PARTS (Cont.)**

**VEND MOTOR SWITCH**

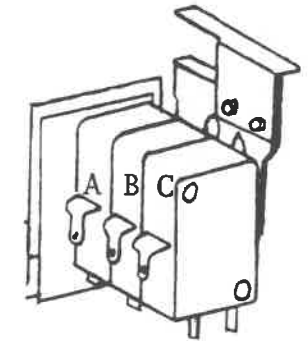

- A. Is Vend Motor Switch
- B. Is Cam-Hold Switch
- C. Is By-Pass Switch

The Vend Motor, the Cam-Hold and the By-Pass switches are together and do not come apart. The Vend Motor Switch, one (1) for each circuit, is located on the Vend Motor Assembly secured by two (2) screws.

The N.C. contact of the Vend Motor Switch is in the Coin Changer Circuit. This N.C. contact opens in the Coin Changer Circuit.

The N.O. contact of the Vend Motor Switch is in the Vend Motor Coil Circuit. This N.O. contact closes in the Vend Motor Coil Circuit to keep the Vend Motor running until the arm of the Vend Motor Switch drops into the cam notch and the Vend Motor stops.

**CAM HOLD SWITCH**

The Vend Motor, Cam-Hold and the By-Pass switches are together and do not come apart. The Cam-Hold switch, one (1) for each circuit, is located on the Vend Motor Assembly secured to a bracket by two (2) screws. This is in the vend motor circuit.

The N.O. contact of the Cam-Hold switch (held closed by the vending cam) is in the Vend Motor circuit. Shortly after the beginning of the vending cycle the arm of the switch (worked by the vending cam) drops into the cam notch and this N.O. contact opens in the circuit to the Select Panel.

When the arm of the switch reaches top side of cam this N.O. contact closes in the circuit to the Select Panel and is still closed at end of the vending cycle.

When the arm of the switch drops into the cam notch, the N.C. contact closes in the Vend Motor Coil Circuit to keep the Vend Motor running. When the arm of the switch reaches top side of cam, this N.C. contact opens in the Vend Motor circuit and is still open at end of the vending cycle.

**BY-PASS SWITCH**

The Vend Motor, the Cam-Hold and the By-Pass switches are together and do not come apart. The By-Pass Switch, one (1) for each circuit, is located on the Vend Motor Assembly secured by two (2) screws. This switch is a by-pass around the Vend Motor Switch to keep the Coin Changer circuit closed if the Vend Motor stops or is stopped when the arm of the Vend Motor Switch is top side of the vending cam, ie, all other vending circuits are operative.



**HOW THE VENDING MECHANISM WORKS (Cont.)****ELECTRICAL PARTS (Cont.)****BY-PASS SWITCH (Cont.)**

The N.O. contact of the By-Pass Switch, there is no N.C. (held closed by the vending cam), is in the Coin Changer Circuit. Shortly after the beginning of the vending cycle, the arm of the switch (worked by the vending cam) drops into the Cam notch and this N.O. contact opens in the Coin Changer Circuit. When the arm of the switch reaches top-side of cam this N.O. contact closes in the Coin Changer circuit and is still closed at end of the vending cycle.

**VEND RELAY****VEND RELAY SWITCH NO. 1 N.C. (There is no N.O.)**

The N.C. contact of Vend Relay Switch No. 1 is the Coin Changer Circuit. This N.C. contact opens and breaks the Coin Changer Magnet Circuit.

**VEND RELAY SWITCH NO. 2 N.O. (There is no N.C.)**

The N.O. contact of Vend Relay Switch No. 2 is in each of the Vend Motor Coil Circuits. This N.O. contact closes in the Vend Motor Coil Circuits to set up these circuits so that a selection can be made.

**VEND RELAY NO. 3 N.O. (There is no N.C.)**

The N.O. contact of Vend Relay Switch No. 3 is in the Vend Relay Coil Circuit. This N.O. contact closes in and keeps the Vend Relay Coil Circuit completed.

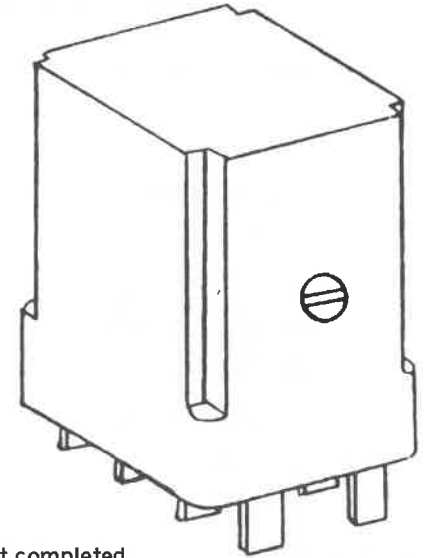
**SEQUENCE RELAY**

The sequence relay is located on a bracket, adjacent to the vend relay (credit relay) on the inner door and secured with two (2) screws.

When a credit is set up by the Coin Changer and the vend relay is energized, the N.O. vend relay switch #2 closes and completes the sequence relay coil circuit.

The sequence relay coil circuit is broken when the N.O. cam hold switch (held closed by the motor cam) opens in the sequence relay coil circuit.

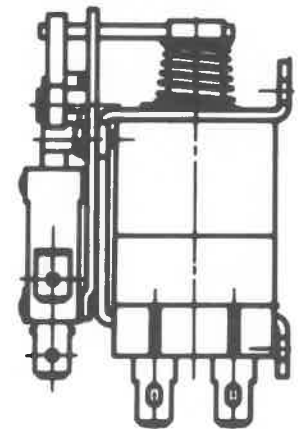

HOW THE VENDING MECHANISM WORKS (Cont.)

VENDING CYCLE AND  
Study-  
ACROSS THE LINE WIRING DIAGRAM

Study the written vending cycle beginning on Page 47 in connection with the across the line wiring diagram. The Across the Line Wiring Diagram can serve as an excellent "trouble shooting chart."

Example: Vender accepts coin.  
Vend relay is energized but immediately "pops" out.

Do this: Look at Across The Line Wiring Diagram and locate:

1. coin vend switch

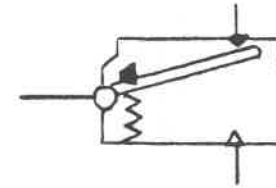

2. vend relay

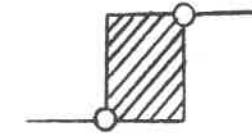

3. vend relay switch No. 1

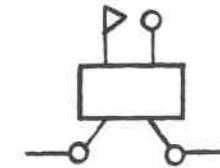

- Observations:
1. Vend relay coil is the affected circuit.
  2. N.O. coin vend switch is in the vend relay coil circuit.
  3. N.O. Vend Relay Switch No. 1 is also in the vend relay coil circuit.
  4. N.O. Vend Relay Switch No. 3 is the "holding switch" for this circuit.

- Conclusions:
1. N.O. Vend Relay Switch No. 1 did not "hold" or keep the circuit closed.

WHY:

- Check:
1. Gap between contacts (too far apart).
  2. Dirt between contact.
  3. Weak coil on Vend Relay.

HOW THE VENDING MECHANISM WORKS (Cont.)

\*-- VEND CYCLE -- (Cont.)

WHAT DOES IT	WHAT HAPPENS
The Vending Cam A coin	Pushes the coin vend switch arm down and;
The N.O. contact of the coin vend switch	Closes and completes the vend relay coil circuit.
The Vend Relay Coil	<p>Closes the N.O. contact of Vend Relay Switch #3 in the Vend Relay Coil Circuit and at the same time,</p> <p>Opens the N.C. contact of Vend Relay Switch No. 1 in the Coin Changer Magnet Circuit and at the same time,</p> <p>Closes the N.O. Contact of vend relay switch No. 2 in the vend motor coil circuits and closes &amp; completes the sequence relay coil circuit.</p>
A spring (in the coin vend switch)	Pulls the vend switch arm back up and,
The N.C. contact of the coin vend switch	Closes in the Vend motor coil circuit,
The customer	Pushes a select button
The select button	Works the N.O. contact of the select switch
The N.O. contact of the select switch	Closes and completes the vend motor coil and the sold out lamp circuit, and
The vend motor	Starts to run and at the same time,
The N.C. contact of the select switch	Opens in the select panel circuit, and at the same time
The Vending Cam	Works the arm of the cam hold switch - - - the arm drops into the cam's notch
The N.O. contact of the Cam Hold Switch (held closed by cam)	Opens in the Select Panel Circuit and opens and breaks the Sequence Relay Coil circuit and at the same time,
The N.C. contact of the Cam Hold switch	Closes in the Vend Motor Coil Circuit to keep the motor turning and at the same time ,

\*Refer to Across the Line Wiring Diagram: C7300.05 or D7220.05

HOW THE VENDING MECHANISM WORKS (Cont.)

\*- VEND CYCLE - (Cont.)

WHAT DOES IT	WHAT HAPPENS
The Vending Cam	Works the arm of the by-pass switch - - - the arm drops into the cam's notch and,
The N.O. contact of the by-pass switch (held closed by cam)	Opens in the Coin Changer Circuit and,
The Vending Cam	Works the arm of the vend motor switch - - - the arm rises to high side of cam and
The N.O. contact of the Vend Motor Switch	Closes in the Vend Motor Coil Circuit to keep the Vend Motor running and at the same time
The N.C. contact of the Vend Motor Switch	Opens and breaks the vend relay coil circuit and,
The N.O. contact of Vend Relay Switch #3	Opens in the vend relay coil circuit and at the same time,
The N.C. contact of Vend Relay Switch #1	Closes in the Coin Changer circuit and the arm of the by-pass switch and the cam hold switch ride to high side of cam and,
The N.O. contact of Vend Relay Switch #2	Opens in the Vend Motor Coil Circuits and rapidly thereafter
The N.O. contact of the by-pass switch	Closes in the Coin Changer Circuit and at the same time.
The N.O. contact of the Cam hold switch	Closes in the Select Panel Circuit and at the same time.
The N.C. contact of the Cam hold switch	Opens in the Vend Motor Coil Circuit and,
The Vending Cam	Continues to work the arm of the vend motor switch and the arm drops into the cam notch and
The N.O. contact of the Vend Motor Switch	Opens and breaks the Vend Motor Coil Circuit - - - the Motor stops and the oscillator stops and,
The N.C. contact of the Vend Motor Switch	Closes in the Coin Changer Circuit.

\*Refer to Across the Line Wiring Diagram: C7300.05 or D7220.05

HOW TO TAKE CARE OF THE VENDER

– WHAT TO CLEAN –

**CABINET**

Wash the vender exterior with either soap and warm water or a good detergent and warm water.

Wash all plastic parts with a mild soap and warm water.

The vender should be waxed often with a good grade of automobile wax.

Any corrosion inside the vender should be removed with fine steel wool and the area should be painted with aluminium paint.

Keep the condenser clean.

**SLUG REJECTOR**

Use a clean cloth to remove loose dirt. A dirty rejector should be cleaned with hot water and a good detergent. Dry it with a clean cloth.

Lubricate only the moving parts of the slug rejector. Oil should not be used on these moving parts.

– WHEN AND WHAT TO LUBRICATE –

HOW OFTEN	PART	LUBRICANT
Every six months	Main Door	Mechanics Friend Mechanics Friend Slipicone
	1. Lock bolt and nut retainer	
	2. Hinge pivot points	
Every year	3. Door gasket, hinge side	Mechanics Friend Mechanics Friend
Every six months	Inner Door	
	1. Latch assembly	
	2. Hinge pivot points	

HOW TO TAKE CARE OF THE VENDER (Cont.)

– THINGS TO ADJUST – (Cont.)

**TEMPERATURE CONTROL** – Ranco No. A12-1558  
Cutler Hammer No. 9531N43

This is a "Constant Cut In" type of control which has two (2) adjustments: They are:

1. The temperature control cam on the outside of the temperature control box.
2. The inside range screw which is under the fibre cover of the temperature control box of the RANCO, and on the side wall of the Cutler Hammer (near terminal cover).

NOTE: The differential screw located between the terminals of the control is sealed and MUST NOT BE CHANGED.

As to No. 1 Adjustment:

The temperature control cam is set in an approximate neutral position. It can be used to make cut out temperature colder by turning the cam clockwise - or - to make the cut out temperature warmer by turning the cam counter clockwise. When the cam is used the cut in temperature (which governs the defrost) remains constant.

As to No. 2 Adjustment:

The inside range screw or screws are used for the altitude adjustment, see altitude below. This screw adjusts both the cut out and cut in settings on the RANCO. It may also be used for colder temperatures by turning the screw counter clockwise or warmer by turning screw clockwise.

On the Cutler Hammer there are two (2) screws provided, one (1) for cut in and one (1) for cut out, both must be adjusted for altitude corrections. For temperature adjustment, turn screws clockwise for colder and counter clockwise for warmer. When adjusting for temperature DO NOT TURN more than 1/8 of a turn at a time. Let the machine run over night before making further adjustment.

**TEMPERATURE CONTROL ALTITUDE ADJUSTMENT**

Control is factory set at altitude of 500 ft. For higher altitudes, control should be adjusted to prevent freeze-up of product. Adjust inside range screw as follows:

ALTITUDE FT;	RANCO SCREW CLOCKWISE	CUTLER-HAMMER BOTH SCREWS COUNTER-CLOCKWISE
2000	¼ turn	1/8 turn
4000	½ turn	¼ turn
6000	¾ turn	½ turn
8000	1 turn	5/8 turn

HOW TO TAKE CARE OF THE VENDER (Cont.)

— THINGS TO ADJUST — (Cont.)

TEMPERATURE CONTROL

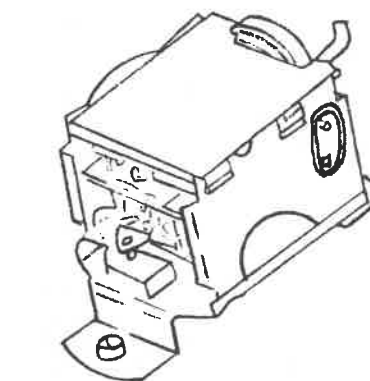

Inside Range Screw

RANCO

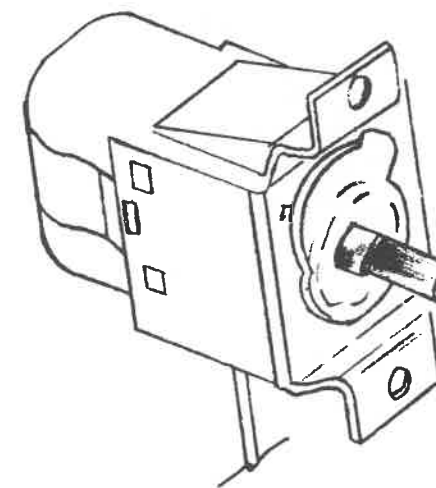

Outside Range Screw



CUTLER — HAMMER

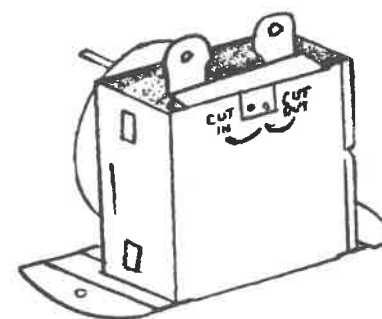

Inside Range Screw

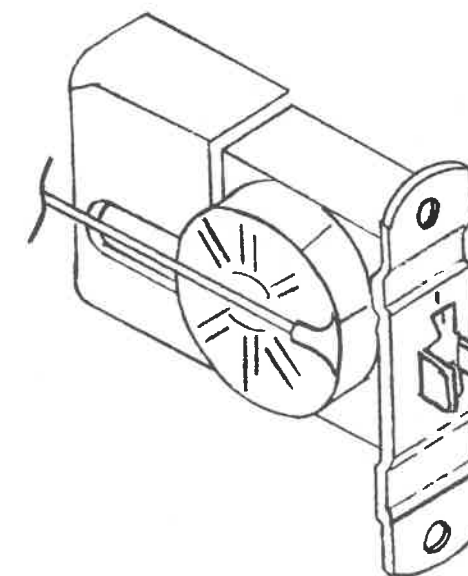

Outside Range Screw



HOW TO TAKE CARE OF THE VENDER (Cont.)

— THINGS TO ADJUST — (Cont.)

**BOTTLE AND CAN ADJUSTMENTS  
STANDARD COLUMN  
LOADING INSTRUCTIONS**

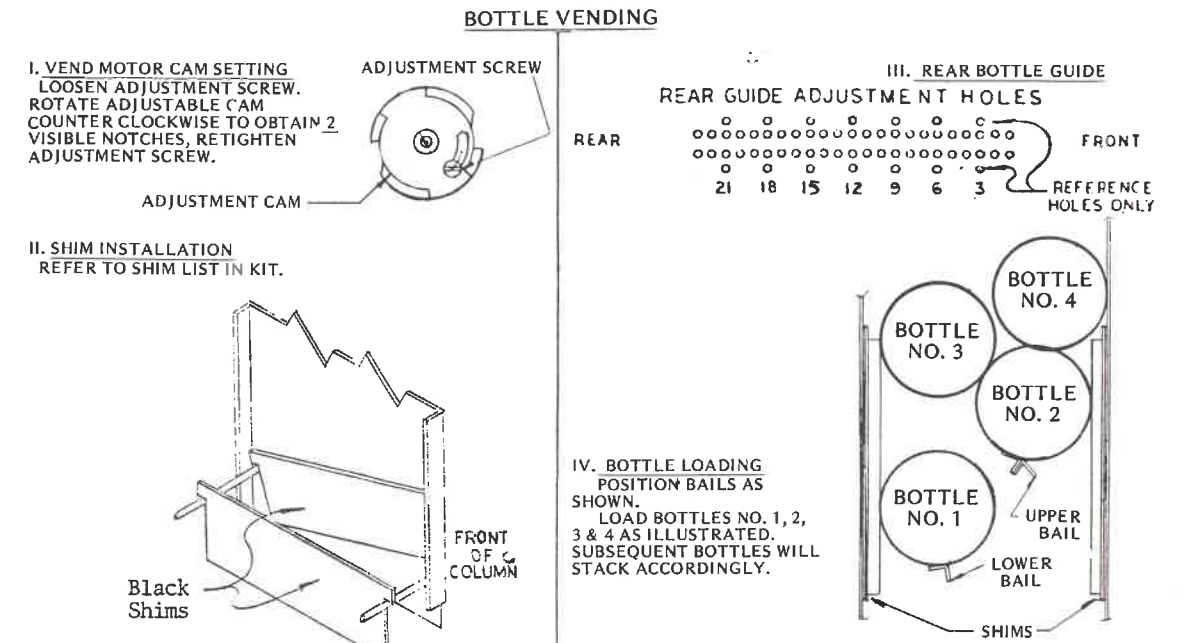

FIG. 1

**STANDARD COLUMN  
LOADING INSTRUCTIONS**

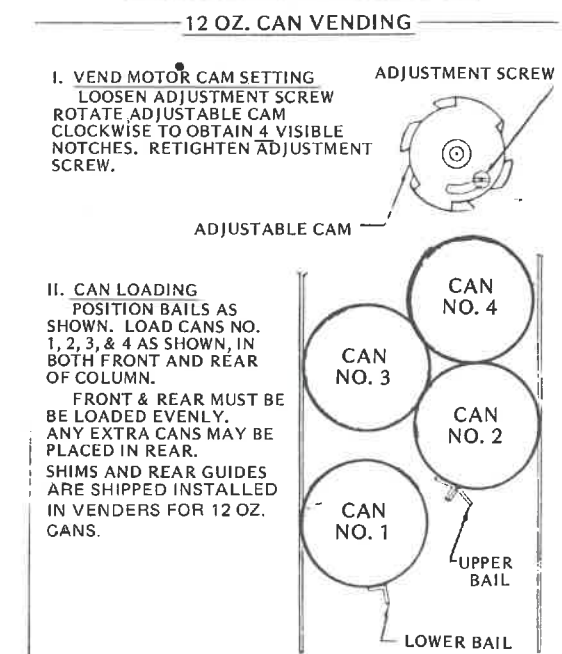

FIG. 2



HOW TO TAKE CARE OF THE VENDER (Cont.)

- THINGS TO ADJUST - (Cont.)

BOTTLE AND CAN ADJUSTMENTS

NARROW COLUMN

BOTTLE VENDING

I. VEND MOTOR CAM SETTING  
 LOOSEN ADJUSTMENT SCREW.  
 ROTATE ADJUSTABLE CAM  
 CLOCKWISE TO OBTAIN 1  
 VISIBLE NOTCH. TIGHTEN  
 ADJUSTMENT SCREW.

ADJUSTMENT SCREW  
 ADJUSTABLE CAM



II. REMOVE EXISTING CAN SHIMS

III. BOTTLE SHIM INSTALLATION  
 REFER TO SHIM LIST IN KIT.

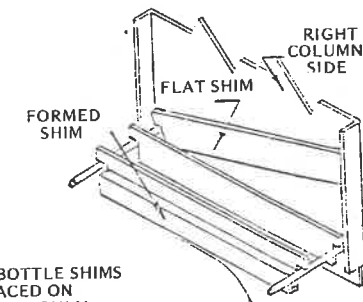

NOTE: BOTTLE SHIMS  
 ARE PLACED ON  
 RIGHT SIDE ONLY.

IV. REAR BOTTLE GUIDE INSTALLATION  
 SEE ILLUSTRATION OF WIDER COLUMN LOADING  
 INSTRUCTIONS.

V. BOTTLE ROD INSTALLATION  
 POSITION ROTOR AS SHOWN  
 AT LEFT BELOW. REFER TO  
 BOTTLE ROD LIST IN KIT.

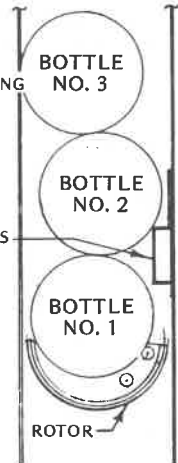
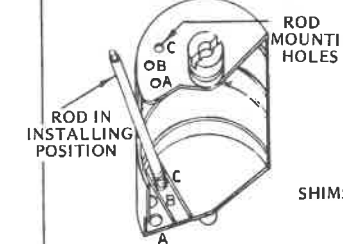

VI. BOTTLE LOADING  
 POSITION ROTOR AS SHOWN  
 AT RIGHT. LOAD BOTTLES NO  
 1, 2, 3 AS ILLUSTRATED.  
 SUBSEQUENT BOTTLES WILL  
 STACK ACCORDINGLY.

FIG. 3

LOADING INSTRUCTIONS

NARROW COLUMN

12 OZ. CAN VENDING

I. VEND MOTOR CAM SETTING  
 LOOSEN ADJUSTMENT SCREW.  
 ROTATE ADJUSTABLE CAM COUNTER  
 CLOCKWISE TO OBTAIN 2 VISIBLE  
 NOTCHES. TIGHTEN ADJUSTMENT  
 SCREW.

ADJUSTMENT SCREW  
 ADJUSTABLE CAM



II. CAN SHIM INSTALLATION

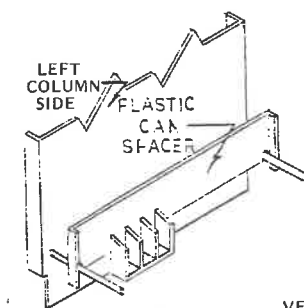

NOTE: CAN SHIMS  
 ARE PLACED ON  
 LEFT SIDE ONLY.

III. CAN LOADING  
 POSITION ROTOR AS  
 SHOWN BELOW. LOAD CANS  
 NO. 1, 2, & 3 AS ILLUSTRATED,  
 IN BOTH FRONT AND REAR  
 OF COLUMN. FRONT AND  
 REAR MUST BE LOADED  
 EVENLY. ANY EXTRA CANS  
 MAY BE PLACED IN REAR.

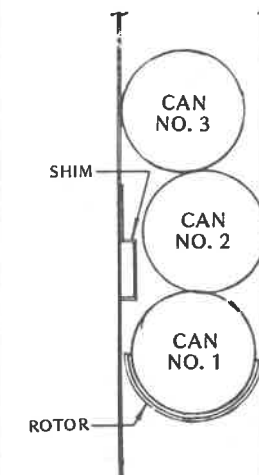

FIG. 4

HOW TO TAKE CARE OF THE VENDER (Cont.)

THINGS TO ADJUST (Cont.)

BOTTLE AND CAN ADJUSTMENTS (Cont.)

Shim Requirements

All of these Models are shipped set to vend 12 oz. Cans i.e.,

1. Rear spacers are installed in Vender, Position No. 19.
2. Two flat shims per standard column are installed in Vender.
3. One shim installed left side of each narrow column.

NOTE: No kit need be ordered for 12 oz. and 16 oz. returnable bottles since shims and rear spacers are shipped with the vender. @Follow shimming instructions below.

KIT	PACKAGE RETURNABLES	WIDE COLUMN	NARROW COLUMN			REAR SPACER POSITION	
		FLAT SHIMS REQUIRED PER COLUMN	SHIMS REQ'D LEFT FORMED	SHIMS REQ'D RIGHT FORMED	FLAT SHIMS RIGHT SIDE		RODS
	@ 12 oz.	2	DO NOT USE IN NARROW COLUMN			18	
	@ 16 oz.	2	DO NOT USE IN NARROW COLUMN			23	
	6 1/2 oz. Coke ##	6	0	1	4	Rear A Front C	
	7 oz. Tab ##	6	0	1	4	Rear A Front C	
	7 oz. Sprite ##	6	0	1	4	Rear A Front C	
	10 oz. Coke ##	6	0	1	4	1 in A*, 1 in C	
	10 oz. Sprite, Tab, Fanta ##	6	0	1	4	1 in A*, 1 in C	
	10 oz. Diet Coke ##	-	-	-	-	-	
	10 oz. Pepsi ##	6	0	1	4	1 in A*, 1 in C	
	10 oz. Diet Pepsi ##	-	-	-	-	-	
	10 oz. Dr. Pepper ##	6	0	1	4	1 in A*, 1 in C	
	10 oz. Diet Dr. Pepper ##	6	0	1	4	1 in A*, 1 in C	
	10 oz. 7-Up ##	6	0	1	4	1 in A*, 1 in C	
2	10 oz. Royal Crown Cola ##	6	0	1	4	1 in A, 1 in C	
	10 oz. Diet Rite Cola ##	6	0	1	4	1 in A*, 1 in C	
	300 ml 10.1 oz. Coke	6	0	1	4	1 in C*, None	
	<u>NON=RETURNABLES</u>						
	10 oz. NR Mountain Dew ## Paper Label	6	0	1	4	Rear A 1 in C Front B	
	10 oz. NR Dr. Pepper ## Paper Label	6	0	1	4	Rear A 1 in C Front B	
	10 oz. NR Coke B ##	2	0	1	2	Rear A 0 Front B	
	10 oz. NR Sprite B ##	2	0	1	2	Rear A 0 Front B	
	10 oz. NR Mello Yello ##	2	0	1	2	Rear A 0 Front B	
3	10 oz. PLB ##	0	1	0	0	0	

1. Where the symbol \* appears, slide the 10 3/4" plastic tube (with kit) over the rod. Use plastic tubing only where called out.
  2. Where Rear A / Front B appears it means that the rod is installed (spring end first) in A (Hole) at rear of vend rotor--the front end of the same rod is installed in B (Hole) at front of vend rotor. See Fig. 2.
  3. Where Rear A / Front C appears it means that the rod is installed (spring end first) in A (Hole) at rear of vend rotor--the front end of the same rod is installed in C (Hole) at front of vend rotor. See Fig. 2.
- ## indicates package is single depth      ### indicates package is double depth

HOW TO TAKE CARE OF THE VENDER (Cont.)

THINGS TO ADJUST (Cont.)

BOTTLE AND CAN ADJUSTMENTS (Cont.)

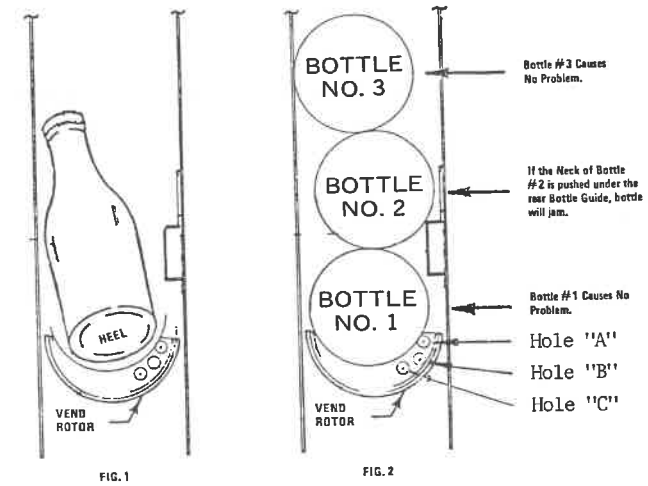

NARROW COLUMNS ONLY (Bottles)  
 Any time Narrow Columns sell out, load first 3 bottles Heel down - Crown up - at approximately 45°. See Fig. 1. Then release to horizontal position, See Fig. 2.

**BOTTLE LENGTH**

THE CLOSURE STRIP AND DISCHARGE MEMBER ARE SET FOR MAXIMUM SECURITY WHEN VENDING CANS. TO VEND BOTTLES REFER TO INSTRUCTIONS BELOW.

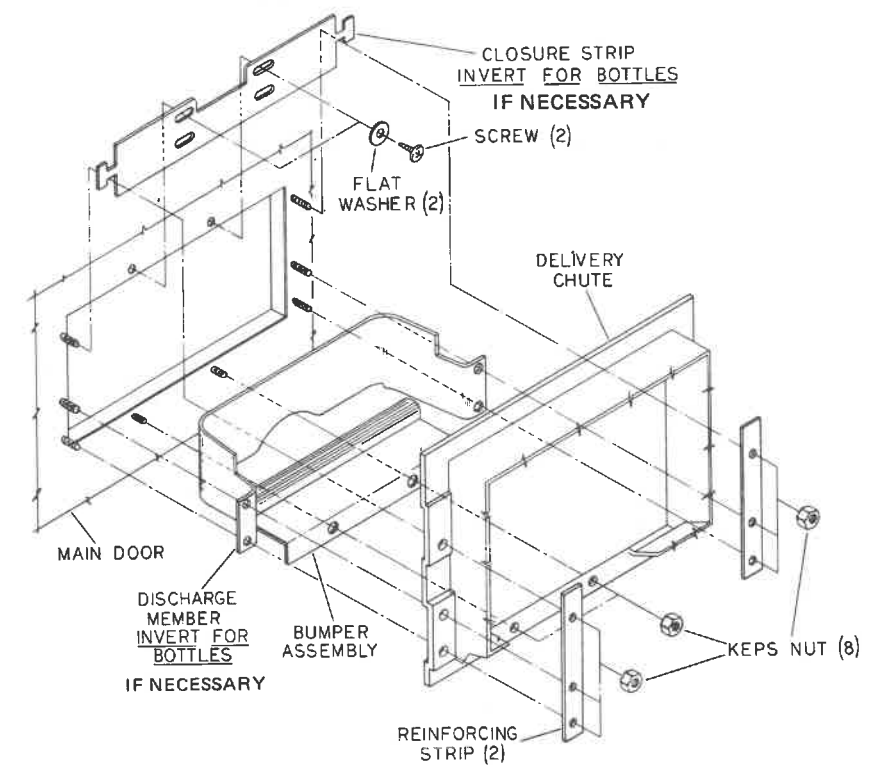

FIG. 1

The closure strip and discharge member are set for maximum security when vending Cans. To Vend Bottles refer to instructions above.

**HOW TO TAKE CARE OF THE VENDER (Cont.)**

– THINGS TO ADJUST – (Cont.)

**BOTTLE AND CAN ADJUSTMENTS (Cont.)**

**ADJUSTMENT SOLD OUT SWITCHES**

The assembly of the front sold out switches is so designed as to provide two (2) different levels of sold out conditions. By removing the cover, the mounting plate supporting the sold out switches can be adjusted to allow the following number of containers to remain in each column when sold out occurs.

Lowest position	1 bottle	2 cans
Second position	2 bottles	4.cans

**ADJUSTMENT & SHIMMING FOR 10 OZ. PLB – WIDE MOUTH**

1. Locate the top of the rear spacer in hole no. 23. Locate the bottom, of the rear spacer as far to the rear as it will go - beyond the holes.
2. Install right hand shim as shown.  
Install left hand shim (not shown) in a similar manner.

Make sure dimension where shown between spring and shim is 1½".

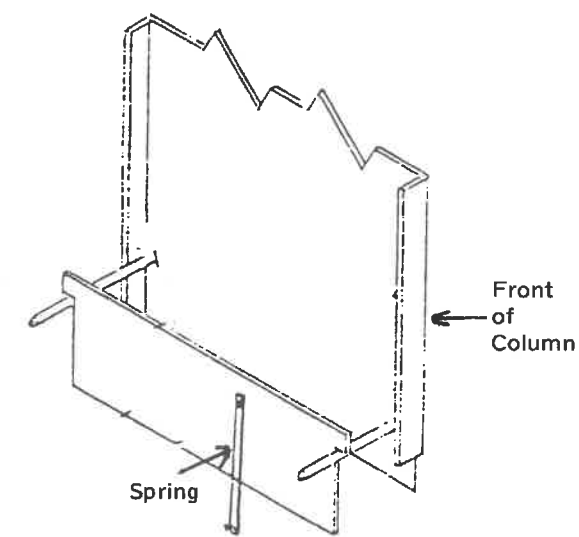

Right Hand Shim Shown

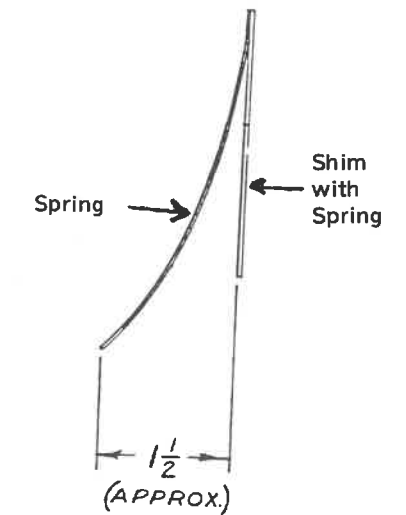

C

C

C

HOW TO CORRECT COMMON VENDING TROUBLES

– (1) ACCEPTS COINS WILL NOT VEND –

– (2) REJECTS ALL GOOD COINS –

It should be remembered that when one (1) or more circuits become inoperative on a Dixie-Narco Vender that has been operating satisfactorily, it is usually (1) component that has failed, and it is with this in mind that the accompanying trouble shooting schematic is presented.

Control Panel  
Electrical Feed  
Thru NC's of Each Select Switch

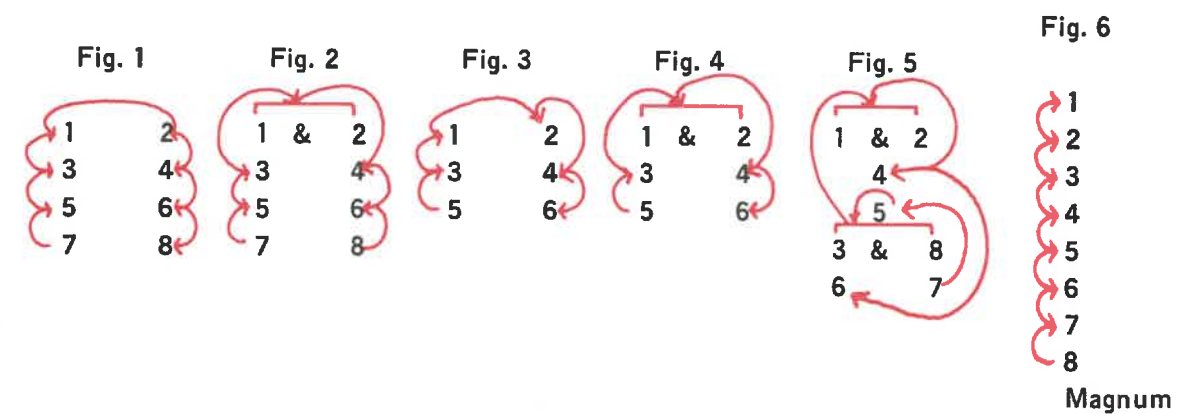

(CONTROL PANEL: Select Button and Select Switch Location)

The control panels shown represent some of the panels used on Dixie-Narco venders.

IMPORTANT to keep in mind is the feed of electrical current thru the select switches. The electrical feed always begins with the largest odd number and proceeds as:

7, 5, 3, 1, 2, 4, 6, 8 (Fig. 1)

or

7, 5, 3, 1 & 2, 4, 6, 8 (Fig. 2)

or

5, 3, 1, 2, 4, 6 (Fig. 3)

or

5, 3, 1 & 2, 4, 6 (Fig. 4)

On the inside of the Control Panel, all select buttons and switches are numbered. If not numbered, then Push Button arrangement is as shown in (1) one of the foregoing diagrams, i.e. Figures 1, 2, 3, or 4.

Figure 5: Figure 5 represents a Control Panel in actual use on a production model vender. (There are other Control Panels similar to it.) The Control Panel is shown to emphasize the need to know the actual location of the various Push Button Select Switches so that the electrical feed can be followed from select switch to select switch as already outlined i.e., 7, 5, 3, 1, 2, 4, 6, 8.

**HOW TO CORRECT COMMON VENDING TROUBLES**  
**(1) ACCEPTS COINS WILL NOT VEND**  
 (Accepts coins - will not vend from (1) or more circuits)

Although all circuit problems are not necessarily found to be (1) one or more inoperative select switches, the examples listed below are typical of select switch problems occurring in the control panel.

Refer to Figure 1:

**PROBLEM 1:** Selections 7 and 5 work.  
 Selections 3, 1, 2, 4, 6, and 8 do not work.  
 Selections 3, 1, 2, 4, 6, and 8 do not work.  
 Recall the feed of electrical current at 7, 5, 3, 1, 2, 4, 6, and 8.

**ANSWER:** Check N.C. & C. of Select Switch 5.

**PROBLEM 2:** Selection 7 works.  
 Selections 5, 3, 1, 2, 4, 6, and 8 do not work.  
 Recall the feed of electrical current.

**ANSWER:** Check N.C. & C. of Select Switch 7.

**PROBLEM 3:** Selections 7, 5, 3, 1, 2, 4, and 6 work.  
 Selection 8 does not work.  
 Recall the feed of electrical current.

**ANSWER:** Check N.C. & C. of Select Switch 6.  
 Check N.O. & C. of Select Switch 8.

Refer to Figure 2:

**PROBLEM 4:** Selection 7 works.  
 Selections 5, 3, 1, 2, 4, 6, and 8 do not work.  
 Recall the feed of electrical current.

**ANSWER:** Check N.C. & C. of Select Switch 7.

**PROBLEM 5:** Selections 7, 5, 3,  $\overline{1 \& 2}$  work.  
 Selections 4, 6, and 8 do not work.  
 Recall the feed of electrical current.

**ANSWER:** Check N.C. & C. of Select Switch  $\overline{1 \& 2}$ .  
 (The symbol  $\overline{\quad}$ , i.e., 1 & 2, indicates that one select switch serves two circuits.)

Refer to Figure 3:

**PROBLEM 6:** Selection 5 works.  
 Selections 3, 1, 2, 4, and 6 do not work.  
 Recall the feed of electrical current.

**ANSWER:** Check N.C. & C. of Select Switch 5.

**HOW TO CORRECT COMMON VENDING TROUBLES**

– (1) ACCEPTS COINS WILL NOT VEND –

– (2) REJECTS ALL GOOD COINS –

It should be remembered that when one (1) or more circuits become inoperative on a Dixie-Narco Vender that has been operating satisfactorily, it is usually (1) component that has failed, and it is with this in mind that the accompanying trouble shooting schematic is presented.

Control Panel  
Electrical Feed  
Thru NC's of Each Select Switch

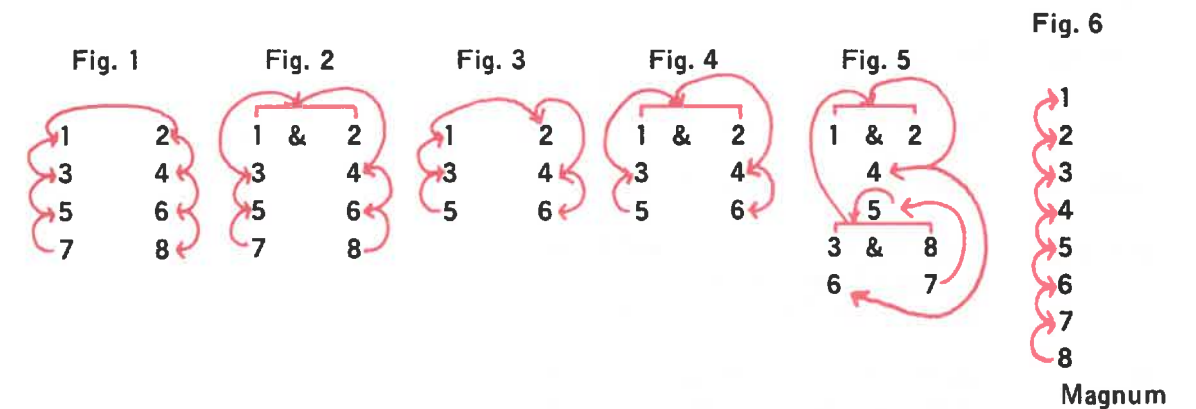

(CONTROL PANEL: Select Button and Select Switch Location)

The control panels shown represent some of the panels used on Dixie-Narco venders.

**IMPORTANT** to keep in mind is the feed of electrical current thru the select switches. The electrical feed always begins with the largest odd number and proceeds as:

- 7, 5, 3, 1, 2, 4, 6, 8 (Fig. 1)
- or
- 7, 5, 3, 1 & 2, 4, 6, 8 (Fig. 2)
- or
- 5, 3, 1, 2, 4, 6 (Fig. 3)
- or
- 5, 3, 1 & 2, 4, 6 (Fig. 4)

On the inside of the Control Panel, all select buttons and switches are numbered. If not numbered, then Push Button arrangement is as shown in (1) one of the foregoing diagrams, i.e. Figures 1, 2, 3, or 4.

Figure 5: Figure 5 represents a Control Panel in actual use on a production model vender. (There are other Control Panels similar to it.) The Control Panel is shown to emphasize the need to know the actual location of the various Push Button Select Switches so that the electrical feed can be followed from select switch to select switch as already outlined i.e., 7, 5, 3, 1, 2, 4, 6, 8.



HOW TO CORRECT COMMON VENDING TROUBLES  
 (1) ACCEPTS COINS WILL NOT VEND  
 (Accepts coins - will not vend from one (1) or more circuits)

— CONTINUED —

Refer to Figure 3:  
 PROBLEM 7:

Selections 5, 3, and 1 work.  
 Selections 2, 4, and 6 do not work.  
 Recall the feed of electrical current.

ANSWER: Check N.C. & C. of Select Switch 1.

Refer to Figure 5:  
 PROBLEM 8:

Selections 7 and 5 work.  
 Selections  $\overline{3 \ \& \ 8}$ ,  $\overline{1 \ \& \ 2}$ , 4 and 6 do not work.  
 Recall the feed of electrical current.

ANSWER: Check N.C. & C. of Select Switch 5.

PROBLEM 9:

Selections 7, 5,  $\overline{3 \ \& \ 8}$ ,  $\overline{1 \ \& \ 2}$  work.  
 Selections 4 and 6 do not work.  
 Recall the feed of electrical current.

ANSWER: Check N.C. & C. of Select Switch 1 & 2.

This symbol  $\overline{\quad}$  i.e.,  $\overline{1 \ \& \ 2}$  and/or  $\overline{3 \ \& \ 8}$  indicates that one (1) Select Switch serves two (2) circuits.

Refer to Figure 4:  
 PROBLEM 10:

Selections 5 and 3 work.  
 Selections  $\overline{1 \ \& \ 2}$ , 4, and 6 do not work.  
 Recall the feed of electrical current.

ANSWER: Check N.C. & C. of Select Switch 3.

**HOW TO CORRECT COMMON VENDING TROUBLES**

– (1) ACCEPTS COINS WILL NOT VEND –

– (2) REJECTS ALL GOOD COINS –

---

**PROBLEM 1:** Accepts coins will not vend.

**EXAMPLE:**

#3 Selection will not vend.

**Check:**

N.O. of #3 Select Switch. (Note: If Sold Out Lamp comes on when button is pushed, select switch is OK.)

**Check:**

Sold Out Switch in vending circuit.

Check: Vend Motor.

---

**PROBLEM 2:** Rejects all good coins.

Coin changer will not accept coins - blocking fingers out.

Put product in each column.

Follow the red arrow WHICH IS THE DIRECTION OF FLOW OF ELECTRICAL CURRENT.

**Do This:**

1. Make sure product is in each column. Sold Out Lamps off.
2. Follow the red arrows from Left to Right.
3.
  - a. Push Vend Motor Switch - Motor F - Vend Motor Cycles.
  - b. Push Vend Motor Switch - Motor E - Vend Motor Cycles.
  - c. Push Vend Motor Switch - Motor D - Vend Motor Cycles.
  - d. Push Vend Motor Switch - Motor C - Vend Motor does not cycle. Problem is Vend Motor Switch and By Pass Switch on Motor C and/or Motor D.
  - e. If problem is not found, continue this procedure through Motors B and A.
  - f. If problem is not found, replace Vend Relay.
  - g. If problem is not found, the last component to check would be the coin changer.

HOW TO CORRECT COMMON VENDING TROUBLES

— (1) ACCEPTS COINS WILL NOT VEND —

— (2) REJECTS ALL GOOD COINS —

Problem 1: Accepts coins will not vend

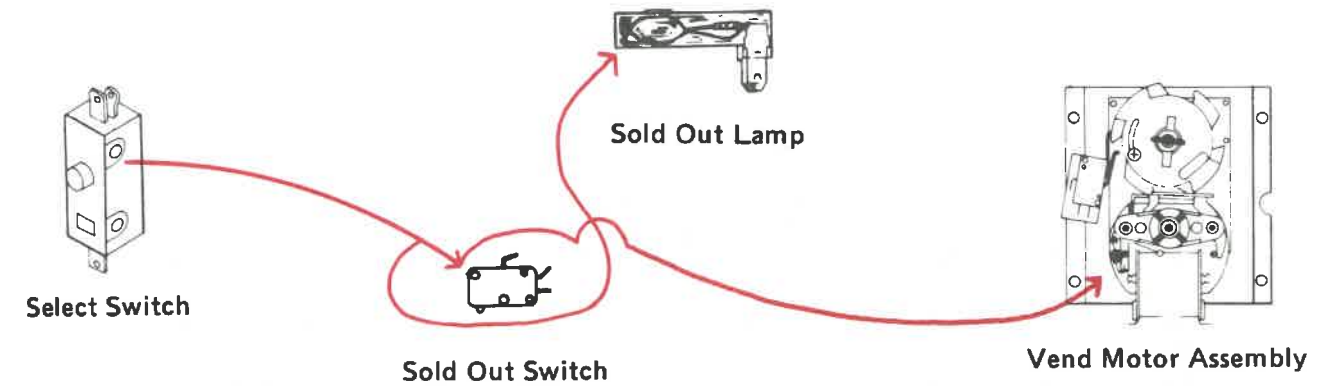

Problem 2: Rejects all good coins

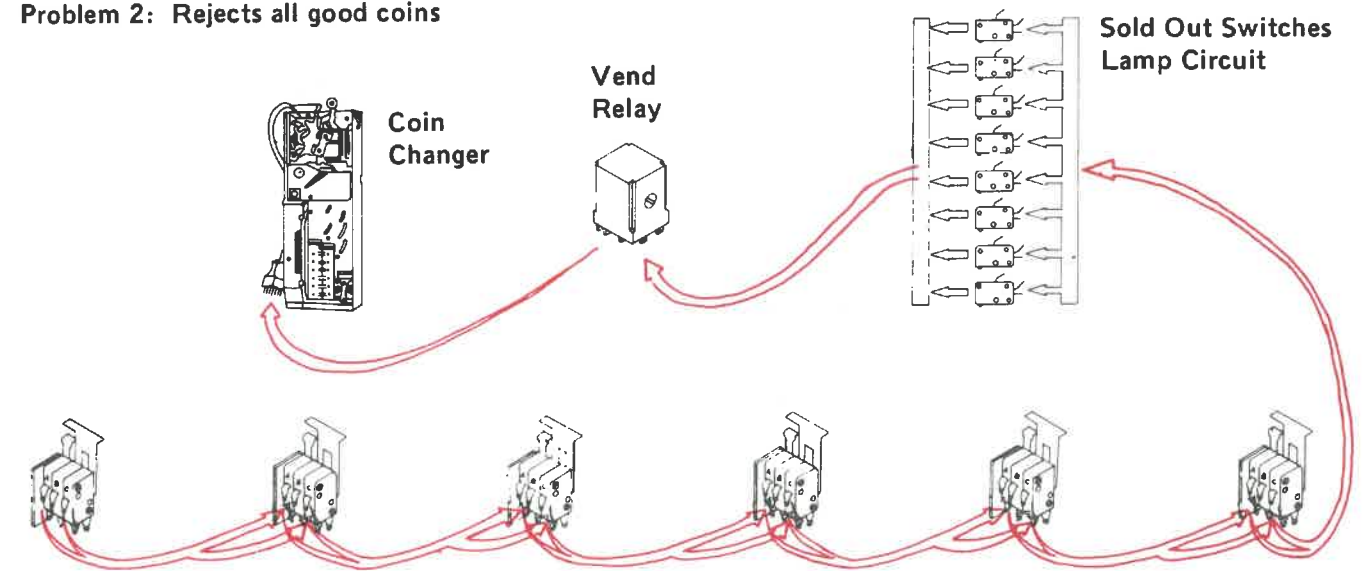

The written procedure on opposite page is a rapid check of both vend motor and bypass switches in the coin changer circuit.

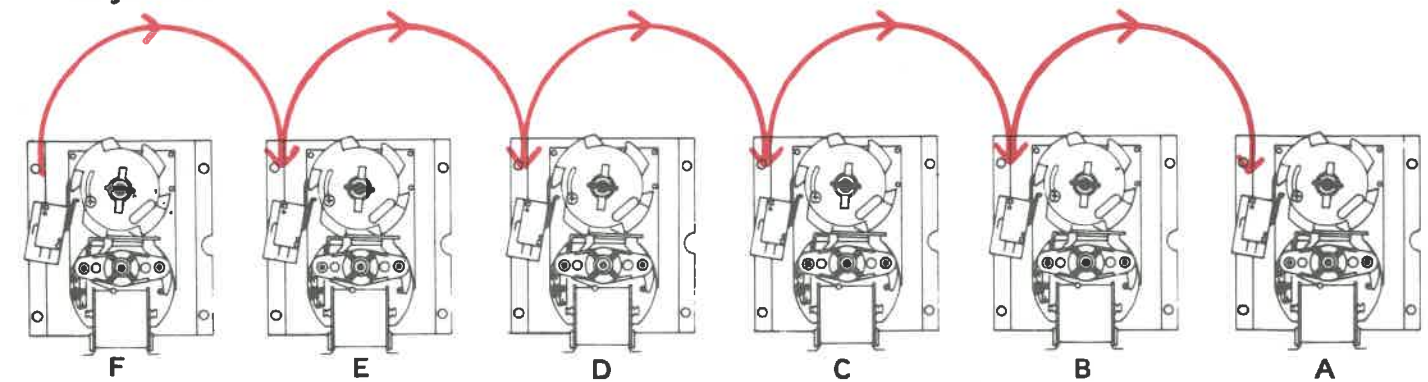

ALL VEND MOTORS IN STAND-BY POSITION

The Red Arrows Show The Directions of Electrical Current Flow

HOW TO CORRECT COMMON VENDING TROUBLES

– (1) ACCEPTS COINS WILL NOT VEND –

Problem:

Set Up Credit

Push All Selections

No Vend

Do This:

1. Unplug Coin Changer
2. Remove Vend Relay
3. Push each Vend Motor switch arm till motor runs and all arms are at bottom of notch. See Motors A through F. Follow Green Arrows

Plug In Cheater Cord

Does Not Correct

Install New Vend Relay

Does Not Correct

Depress Cheater Cord

Motor A Cycle

Depress Cheater Cord

Motor B Cycle

Depress Cheater Cord

Motor C Cycle

Example: If Motor C does not cycle then problem is Cam/ Hold Switch on Motor C or Motor B.

Now Continue,  
Depress Cheater Cord

Motor D Cycle

Depress Cheater Cord

Motor E Cycle

Depress Cheater Cord

Motor F Cycle

If still no correction,  
Continuity test Cam/Hold Switch Motor F

If still no correction,  
Continuity test #5 Select Switch

HOW TO CORRECT COMMON VENDING TROUBLES

– (1) ACCEPTS COINS WILL NOT VEND –

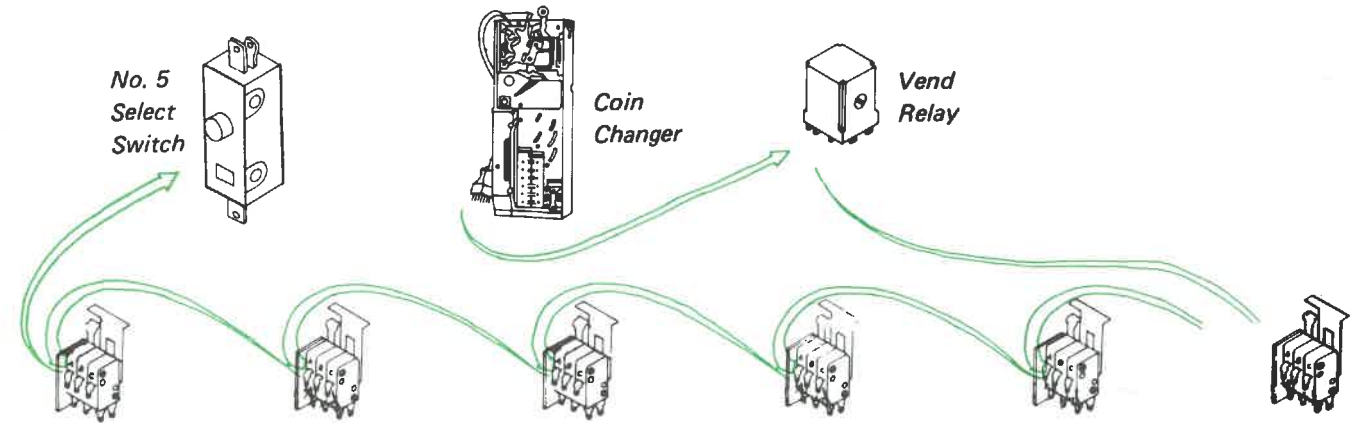

THE GREEN ARROWS SHOW THE DIRECTION OF ELECTRICAL CURRENT FLOW

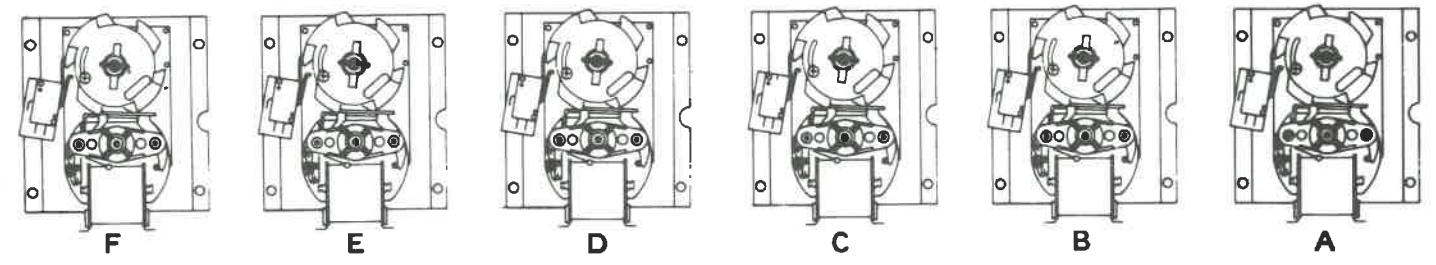

ALL SWITCH ARMS ARE SHOWN IN CAM NOTCH

DIXIE-NARCO

HOW TO CORRECT COMMON VENDING TROUBLES

- REJECTS ALL GOOD COINS -

A POSSIBLE CAUSE IS	TO MAKE SURE	THIS IS WHAT TO DO
Vendor not plugged in	Look, if not	Plug the vender in.
Slug rejector is neither vertical nor level.	Look at it and try a coin. If coin is rejected,	Level the vender.
Blocking fingers remain in coin path.	Remove the Slug Rejector - unplug the vender. Touch prods of test lamp to either side of electro magnet coil, lamp should light, if it doesn't,	Put in a new coil or magnet coil assembly.
The coin paths are dirty	Remove the slug rejector,,look at it, if it is dirty,	Clean it with warm water, a good detergent. Dry it thoroughly.
The slug rejector is out of adjustment or the scavenger gate is not closed.	Remove the slug rejector. Put a coin in, if it rejects the coin,	Adjust the slug rejector.
Low voltage.	Check with a volt-meter, if voltage is low,	Correct with location outlet.
N.C. contact of Vend Relay Switch #1.	Put prods of test lamp to N.C. and C. contact. Lamp should light, if it doesn't,	Clean contact with approved cleaner or install new relay.
*N.O. contact of By Pass Switch and	Push switch arm back - put prods of test lamp to N.O. and C. contact Lamp should light, if it doesn't,	Replace switch.
*N.C. contact of Vend Motor Switch.	Put prods of test lamp to N.C. and C. contact. Lamp should light, if it doesn't,	Replace Switch.

\*These two (2) switches combined and in the same circuit can break the circuit to the Coin Changer.

HOW TO CORRECT COMMON VENDING TROUBLES (Cont.)

– ACCEPTS COINS BUT DOES NOT LET A CAN OR BOTTLE VEND FROM ANY COLUMN –

A POSSIBLE CAUSE IS	TO MAKE SURE	THIS IS WHAT TO DO
Vend Switch Coin Changer.	Put the prods of a test lamp to N.C. and C. contacts. Lamp should light, if it doesn't,	Put in a new Vend Switch.
Vend Switch Coin Changer.	Put the prods of a test lamp to N.O. and C. contacts. Push the switch arm down, lamp should light, if it doesn't,	Put in a new Vend Switch.
Vend Relay Coil.	Put the prods of a test lamp to either side of the coil. Lamp should light, if it doesn't,	Put in a new Vend Relay.
N.O. contact of Vend Relay Switch #2.	Energize Vend Relay Coil. If contact does not touch or if it touches but still inoperative,	Clean contact with approved cleaner or put in new relay.
N.C. contact of Select Switch #5.	Put the prods of a test lamp to N.C. and C. contacts. Lamp should light, if it doesn't,	Put in a new Select Switch.
N.O. contact of any cam hold switch.	Push switch arm back. Put prods of test lamp to N.O. and C. Lamp should light, if it doesn't,	Put in a new Cam hold Switch.
N.O. contact of Vend Relay Switch #3.	Energize Vend Relay Coil. If contact does not touch or it touches and then opens,	Clean contact with approved cleaner or put in new relay.



HOW TO CORRECT COMMON VENDING TROUBLES (Cont.)

– ACCEPTS COINS BUT DOES NOT LET A CAN OR BOTTLE VEND FROM A GIVEN COLUMN –

A POSSIBLE CAUSE IS	TO MAKE SURE	THIS IS WHAT TO DO
Vend Motor.	Put the prods of a test lamp to either side of the coil. Lamp should light, if it doesn't,	Put in a new vend motor.
N.O. contact of Vend Motor Switch.	Push switch arm back. Put the prods of a test lamp to N.O. and C. contacts. Lamp should light, if it doesn't,	Put in a new vend motor switch.
N.O. contact of Vend Motor Switch.	Put the prods of a test Lamp to N.O. and C. contacts. Lift switch arm up, lamp should light, if it doesn't,	Put in a new switch.
N.O. contact of a Select Switch.	Push switch arm back. Put the prods of a test lamp to N.O. and C. contacts. Lamp should light, if it doesn't,	Put in a new switch.
N.C. contact of a Sold Out Switch in a Vending Circuit.	Put the prods of a test lamp to N.C. and C. contacts. Lamp should light, if it doesn't,	Put in a new switch.
N.C. contact Coin Vend Switch.	Put the prods of a test lamp to N.C. and C. contacts. Lamp should light, if it doesn't,	Put in a new Vend Switch.
N.O. contact of Vend Relay Switch #2.	Energize Vend Relay Coil. If contact does not touch or if it touches and then opens,	Clean contact with "Cobehn" or put in new relay.

**HOW THE REFRIGERATION SYSTEM WORKS**

**– MECHANICAL PARTS –**

**COMPRESSOR MOTOR**

The compressor motor (sealed in the compressor housing) drives the compressor with a shaft that is shared by both parts.

**COMPRESSOR**

The compressor (sealed in the compressor housing) sucks cold, low pressure freon gas from the evaporator and pumps hot, pressure freon gas out to the condensor.

**CONDENSER**

The condenser, located in the base of the vender, at the front, takes heat out of the hot, high pressure gas that comes from the compressor. The gas loses heat as it goes through the condenser coils, and changes into a liquid because it is still under high pressure.

**CONDENSER FAN**

The condenser fan (between the condenser and motor compressor) first sucks air from the outside of the vender through the condenser. This air takes heat from the condenser first and then is blown over the compressor housing from which it also takes heat before going back outside of the vender. The condenser fan runs when the motor compressor runs.

**MOLECULAR STRAINER DRYER**

The molecular strainer dryer is in the liquid line between the condenser and the capillary tube. This dryer traps and holds water molecules but lets oil molecules and freon molecules go through into the capillary tube.

**CAPILLARY TUBE**

The capillary tube (between the condenser and the evaporator in the refrigerant line) has a very small inside diameter, so the flow of the liquid freon from the condenser into the evaporator is slow, but steady, even with the pressure the compressor builds up in the condenser. This helps to keep the pressure in the evaporator low.

**HOW THE REFRIGERATION SYSTEM WORKS (Cont.)****— ELECTRICAL PARTS — (Cont.)****EVAPORATOR**

The evaporator (in the vender cabinet) takes heat from the air in the vender cabinet and gives this heat to the liquid refrigerant. The liquid refrigerant is evaporated (boiled off) as a gas, and the gas is sucked out by the compressor and so the pressure is kept low.

**EVAPORATOR FAN**

The evaporator fan sucks warm air from around the cans or bottles in the cooling compartment and blows it across the evaporator. As the air goes across the evaporator, it gives up heat to the evaporator. As the air goes across the evaporator, it gives up heat to the evaporator, then goes back to the cans or bottles, and takes heat from them. This fan runs all the time when the vender is plugged in.

**CONDENSATE PAN**

The condensate pan (located in the compressor compartment) collects the water which runs from the vender during the defrost cycle. The water is evaporated into the surrounding air by means of soakers, and the air movement resulting from the condenser fan blade rotation. The soakers extend down into the pan to absorb the water. Exposure to the surrounding air vaporizes the water in the soakers, and the water vapor is carried into the air by the action of the condenser fan blade.

**— ELECTRICAL PARTS —****TEMPERATURE CONTROL**

The temperature control is the name of a part that is made up of a control bulb connected by a small metal tube to a bellows. The control bulb is in a tube back of the evaporator. The bellows and a switch known as the temperature control switch are in the temperature control box which is fastened to the right side inside the vender.

The control bulb and the bellows have a vapor in them. When the temperature of the vapor in the bulb rises, it builds up pressure in the bellows tube. This pushes the bellows out, makes it longer. When the control bulb is cool the vapor shrinks back, and the bellows pull in and get shorter. These movements of the bellows work the switch — called the temperature control switch — closing it when the bulb is heated and opening it when the bulb is cooled.

**HOW THE REFRIGERATION SYSTEM WORKS (Cont.)**

**– ELECTRICAL PARTS – (Cont.)**

**TEMPERATURE CONTROL (Cont.)**

The contacts of the temperature control switch are in the compressor motor's running and starting circuits. They are also in the condenser fan motor circuit.

When the cabinet temperature gets up to the cut-on setting, the temperature control switch closes in the compressor motor's starting and running circuits and in the condenser fan circuit. When the cabinet temperature gets down to the cut-off setting, the temperature control switch opens in these circuits.

CAUTION: To adjust temperature control see pages 18 and 19 "Things To Adjust."

**STARTING RELAY**

The starting relay (in the terminal box on the side of the compressor shell) is an electromagnetic relay whose contacts are closed by the magnetic field of the relay coil, and are opened by gravity. It is made up of a relay coil and one set of contacts. The relay coil is in the running circuit of the compressor motor. The relay contacts are in the compressor motor's starting circuit and can complete or break only that circuit.

When the compressor motor and the condenser fan motor first start, the starting relay closes and completes the compressor motor starting, winding circuit. After the compressor motor gets up speed, the starting relay is opened by the force of gravity and the starting winding circuit is broken.

**COMPRESSOR MOTOR**

The compressor motor (sealed in the compressor housing) runs the compressor. It is started by the temperature control switch, the starting relay and the thermal overload switch. It is stopped by the temperature control switch, and, if it gets overloaded, by the thermal overload switch.

**HOW THE REFRIGERATION SYSTEM WORKS (Cont.)****– ELECTRICAL PARTS – (Cont.)****THERMAL OVERLOAD ASSEMBLY**

The thermal overload assembly (in the terminal box on the side of the compressor shell) is the name of a part that is made up of a switch (the thermal overload switch) and a heating wire. The heating wire is in the compressor motor's running and starting circuits. The thermal overload switch can complete or break the compressor motor's starting circuit and running circuit. If the compressor motor gets too warm, or draws too much current (which will make the heating wire get hot) the heat makes the thermal overload switch open in the running and starting circuit of the compressor and break those circuits. When the thermal overload assembly, the motor, and the compressor shell have all cooled enough to run safely, the thermal overload switch closes in these circuits and completes them.

**CONDENSER FAN MOTOR**

The condenser fan motor (between the condenser and the motor compressor) runs a fan that sucks air through the condenser coils. It starts when the temperature control switch is closed and it stops when the temperature control switch is open.

HOW THE REFRIGERATION SYSTEM WORKS (Cont.)

– ELECTRICAL OPERATION –

WHAT DOES IT	WHAT HAPPENS
<b>WHEN THE VENDER TEMPERATURE GETS UP TO THE CUT-ON SETTING</b>	
The temperature control switch	<p>Closes in the running winding circuit of the compressor motor and completes that circuit.</p> <p>Closes in the starting relay coil circuit, and completes that circuit.</p> <p>Closes in the starting winding circuit of the compressor motor.</p> <p>Closes in the condenser fan motor circuit, completing the circuit.</p>
<b>THE HEAVY CURRENT, DRAWN BY THE RUNNING WINDING, ALSO FLOWS IN THE STARTING RELAY COIL, AND:</b>	
The starting relay coil	Closes the starting relay contacts in the starting winding circuit of the compressor motor, completing that circuit.
<b>WHEN THE COMPRESSOR MOTOR GETS UP TO SPEED</b>	
The force of gravity	Pulls the starting relay contacts apart because
The starting relay coil	No longer gets enough current to hold the contacts closed, and
The starting relay contacts	Open in the starting winding circuit of the compressor motor, and break that circuit.
<b>IF EITHER THE COMPRESSOR MOTOR OR THE CONDENSER FAN DRAWS TOO MUCH CURRENT AND CAUSES THE THERMAL OVERLOAD ASSEMBLY TO GET TOO WARM</b>	
The thermal overload switch	Opens in the running winding circuit and the starting winding circuit of the compressor motor, and breaks both those circuits.

HOW THE REFRIGERATION SYSTEM WORKS (Cont.)

- ELECTRICAL OPERATION - (Cont.)

WHAT DOES IT	WHAT HAPPENS
<b>WHEN THE THERMAL OVERLOAD ASSEMBLY COOLS DOWN AGAIN</b>	
The thermal overload switch	Closes in both the running winding circuit and the starting winding circuit of the compressor motor.
<b>WHEN THE VENDER TEMPERATURE GETS DOWN TO THE CUT-OFF SETTING</b>	
The temperature control switch	<p>Opens in the running winding circuit of the compressor motor, and breaks that circuit.</p> <p>Opens in the starting relay coil circuit, and breaks that circuit.</p> <p>Opens in the starting winding circuit of the compressor motor.</p>

HOW THE REFRIGERATION SYSTEM WORKS (Cont.)

– ELECTRIC CIRCUITS AND CIRCUIT DIAGRAMS –

CONDENSER FAN CIRCUIT

SWITCHES IN THE WIRING	WHAT THE SWITCHES DO	WHAT MAKES THE SWITCHES WORK
Temperature control switch	Turns the condenser fan motor on and off.	The temperature in the vender has come up to the cut-on point (or gotten down to the cut-off point) set on the temperature control.

COMPRESSOR MOTOR RUNNING WINDING CIRCUIT

SWITCHES IN THE WIRING	WHAT THE SWITCHES DO	WHAT MAKES THE SWITCHES WORK
Thermal overload switch	Turns the running windings of the compressor motor on.	Current drawn by the motor or heat from the compressor can raise the temperature of the thermal overload assembly and make the thermal overload switch cut off.





HOW THE REFRIGERATION SYSTEM WORKS (Cont.)

- ELECTRIC CIRCUITS AND CIRCUIT DIAGRAMS - (Cont.)

CONDENSER FAN CIRCUIT DIAGRAM

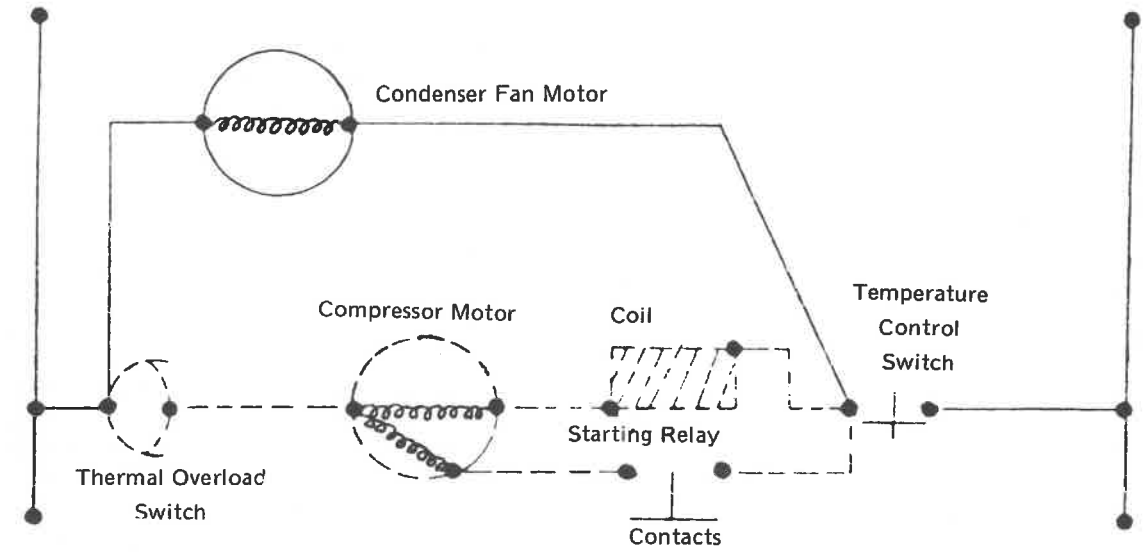

COMPRESSOR MOTOR RUNNING WINDING CIRCUIT DIAGRAM

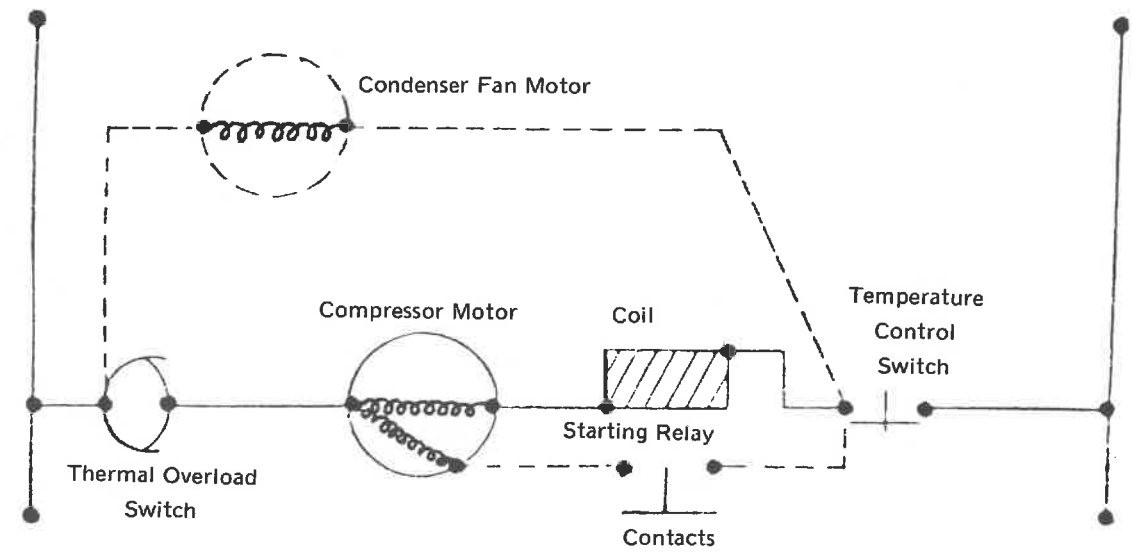

**HOW THE REFRIGERATION SYSTEM WORKS (Cont.)**  
 – ELECTRIC CIRCUITS AND CIRCUIT DIAGRAMS – (Cont.)

**COMPRESSOR MOTOR STARTING WINDING CIRCUIT**

SWITCHES IN THE WIRING	WHAT THE SWITCHES DO	WHAT MAKES THE SWITCHES WORK
Temperature control switch	Turns the starting windings of the compressor motor on.	The temperature in the vender has come up to the cut on point set on the temperature control.
Starting relay contacts	Turns the starting windings of the compressor motor on and off.	The current drawn by the running winding of the com- pressor motor when it is first turned on also closes through the starting coil. This heavy current gives the relay coil enough power to close the contacts.
Thermal overload switch	Turns the starting windings of the compressor motor on and off.	Current drawn by the motor or heat from the com- pressor can raise the temperature of the thermal over- load assembly and make the thermal overload switch open.

HOW THE REFRIGERATION SYSTEM WORKS (Cont.)  
- ELECTRIC CIRCUITS AND CIRCUIT DIAGRAMS - (Cont.)

COMPRESSOR MOTOR STARTING WINDING CIRCUIT DIAGRAM

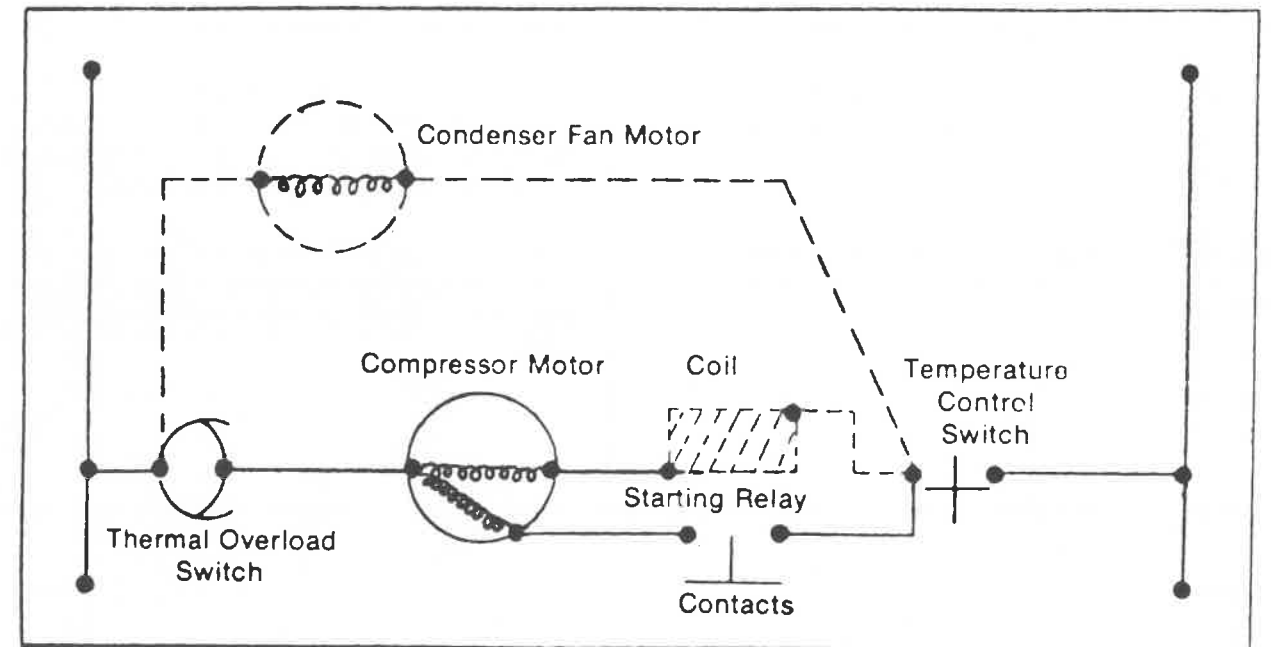

## HOW THE REFRIGERATION SYSTEM WORKS (Cont.)

## — REFRIGERATION CYCLE —

<u>What Does It</u>	<u>What Happens</u>
The rising temperature in the vender	Warms the temperature control bulb and the liquid in it.
The liquid in the control bulb.	Expands and pushes through the control tube and stretches the temperature control bellows.
The bellows	Moves, and closes the temperature control switch.
The temperature control switch	Turns the compressor motor on. Turns the condenser fan motor on.
The compressor motor	Drives the compressor.
The condenser fan motor	Drives the condenser fan.
The condenser fan motor	Sucks air through the condenser, cooling it.
The compressor	Sucks low pressure refrigerant gas from the evaporator, compresses the gas, and pumps it to the condensor.
The cooled condenser	Takes the heat out of the high pressure refrigerant gas.
The cooled gas	Turns into liquid refrigerant.
More hot gas coming from the compressor	Pushes the liquid refrigerant into the capillary tube.
The capillary tube	Lets only a certain amount of liquid refrigerant run into the evaporator.
The evaporator	(Where the pressure is kept low by the suction of the compressor) heats the liquid refrigerant.
The liquid refrigerant	Changes into gas at low pressure and is sucked below into the compressor.
The falling temperature in the vender	Cools the temperature control bulb and the liquid in it.

**HOW THE REFRIGERATION SYSTEM WORKS (Cont.)**

**— REFRIGERATION CYCLE — (Cont.)**

<u>What Does It</u>	<u>What Happens</u>
The liquid in the control bulb	Shrinks, and lets the temperature control bellows pull back
The bellows	Move, and open the temperature control switch.
The temperature control switch	Turns the compressor motor off. Turns the condenser fan motor on.
The compressor	Stops.
The condenser fan motor.	Stops.

(With the vender "Plugged In" the evaporator fan motor runs constantly)

**HOW TO TAKE CARE OF  
THE REFRIGERATION SYSTEM**

**— WHAT TO CLEAN —**

Clean dirt and lint from the condenser with a brush, vacuum cleaner or compressed air

**— WHEN AND WHAT TO LUBRICATE —**

The refrigeration system is sealed up and does not have to be oiled or greased. Enough oil is put into the condenser and evaporator fan motors when they are manufactured to last as long as they will run.

**— CORRECTING TROUBLES —**

When the refrigeration system is not working right, go to the table called "Correcting Common Refrigeration Troubles" on the next pages. Find your trouble, see what the possible causes are, and try the tests (in the center column): they will let you know when you have the true cause of the trouble. When you have found the cause of the trouble, either make the adjustment, repair the part or put a new part in, whatever the table says to do. This table does not list all of the possible causes of any of the troubles — but it does have all of the common causes. If your vender has a trouble that is not shown on the chart, or the trouble is not the result of one of the causes shown on the chart, study the section on "How The Refrigeration Mechanism Works" and you will be able to find out what is wrong and fix it.

**HOW TO CORRECT  
COMMON REFRIGERATION TROUBLES**

**TROUBLE**

THE COMPRESSOR WILL NOT RUN AT ALL . . . . . 52

THE COMPRESSOR STARTS BUT WILL NOT KEEP RUNNING . . . . . 54

THE COMPRESSOR RUNS BUT THE CANS/BOTTLES AREN'T COLD ENOUGH . . . . . 56

THE CANS/BOTTLES ARE TOO COLD . . . . . 59

THE REFRIGERATION UNIT IS NOISY . . . . . 59

THE COMPRESSOR MOTOR NEVER STOPS RUNNING . . . . . 60

**HOW TO CORRECT  
COMMON REFRIGERATION TROUBLES (Cont.)  
THE COMPRESSOR WILL NOT RUN AT ALL**

A POSSIBLE CAUSE IS	TO MAKE SURE	THIS IS WHAT TO DO
1. The vender is not plugged in.	Look, and if it isn't,	Plug the vender in.
2. The power is off.	Plug a 110V lamp into the outlet, if it doesn't light.	Have someone who knows how, get power to the outlet.
3. The refrigeration unit is not made for the voltage it is getting.	Look at the nameplate on the vender to find out what voltage and cycle it is made for. Ask the local power company if they supply this kind of current. If they don't,	Put a vender in that is made for the kind of current you are getting.
4. A wire in the supply cord or control cable is broken.	Put the prods of 110V test lamp on terminal L of the starting relay and on terminal 3 of thermal overload switch (make sure the temperature control switch is closed). If it doesn't light.	Put a new supply harness on
5. The thermal overload switch is stuck open.	Unplug the vender for at least 15 minutes. Then plug the vender in and put the prods of a 110V test lamp on terminal L of the starting relay and on the common terminal of the compressor motor. If the lamp doesn't light.	Put a new thermal overload assembly in.
6. The temperature control bulb is either touching the evaporator or it is covered with ice and frost.	Look at it. If it is touching the evaporator or is covered with ice or frost.	Defrost the evaporator and be sure the bulb is mounted right.



**HOW TO CORRECT  
COMMON REFRIGERATION TROUBLES (Cont.)**

**THE COMPRESSOR WILL NOT RUN AT ALL (Cont.)**

A POSSIBLE CAUSE IS	TO MAKE SURE	THIS IS WHAT TO DO
7. The temperature control bellows do not work.	Warm the temperature control bulb with your hand for about one minute. If the temperature control switch doesn't close,	Put a new temperature control in.
8. The temperature control switch contacts need cleaning.	Clean them and see if this helps.	Clean the faces of the contacts with "Cobehn."
9. The starting relay contacts aren't closing.	Warm the temperature control bulb to close the temperature control switch. If the starting relay contacts don't close at the same time.	Check the relay out as explained in the next two steps. If they do close, skip the next two steps and go on to step twelve of this section.
10.	Put the prods of a 110V test lamp across M of the relay and 3 of the overload protector. If the lamp does not light.	Put in a new relay.
11. The starting relay contacts are stuck open.	Warm the temperature control bulb to close the temperature control switch. If the starting relay contacts don't close when the temperature control switch does,	Put a new starting relay in.
12. The compressor motor's starting or running winding is burned out.	Unplug the vender. Take all wires off the compressor terminals. Connect a 110V line to compressor motor terminals (C) and (R). At once, with an insulated wire, connect (for 2 seconds) compressor terminals (R) and (S). If the compressor does not start,	Put a new motor compressor in.

**HOW TO CORRECT  
COMMON REFRIGERATION TROUBLES (Cont.)  
THE COMPRESSOR STARTS, BUT WILL NOT KEEP RUNNING**

A POSSIBLE CAUSE IS	TO MAKE SURE	THIS IS WHAT TO DO
<p>1. The thermal overload switch opens every time, or almost every time, the compressor motor starts.</p>	<p>Wait until the compressor motor stops then unplug the vender and open the temperature control. See if switch is closed. If it is,</p>	<p>Check The "Possible Causes" in the next 6 steps. If it is not, skip the next 6 steps and go to step 8 of this section.</p>
<p>2. The tube from the compressor to the condenser is kinked or bent sharply.</p>	<p>Look, if it is,</p>	<p>Try to get the kink out</p>
<p>3. The capillary tube is kinked or bent sharply,</p>	<p>Look, if it is,</p> <p>If this does not help and no other cause can be found for the trouble,</p>	<p>Try to get the kink out</p> <p>Put a new capillary tube on</p>
<p>4. The starting relay contacts are sticking closed.</p>	<p>Plug the vender back in. Then while the compressor is running see if the starting relay contacts stay closed. If they do,</p> <p>If the starting relay contacts stick closed again after cleaning.</p>	<p>Clean the relay contacts with "Cobehn"</p> <p>Put a new starting relay in</p>
<p>5. The voltage at the vender is either too high or too low.</p>	<p>1. When an extension cord is not used on the supply cord. While the compressor is running put one prod of a volt meter on terminal (L) of the starting relay and the other prod on terminal (M) of the starting relay. If the voltage is not between 105V and 126V.</p>	<p>Have the person in charge of the vender tell the power company so they can take care of it.</p>

**HOW TO CORRECT  
COMMON REFRIGERATION TROUBLES (Cont.)  
THE COMPRESSOR STARTS, BUT WILL NOT KEEP RUNNING (Cont.)**

A POSSIBLE CAUSE IS	TO MAKE SURE	THIS IS WHAT TO DO
	<p>2. When an extension is used on the supply cord. Put a double socket on the plug end of the extension and plug it into the outlet. While the compressor is running, put the prods of a volt meter into one of the other sides of the double socket. If the voltage is not between 105V and 126V.</p>	<p>Have the person in charge of the vender tell the power company so they can take care of it.</p>
<p>6. The cut-on temperature is set too close to the cut-off temperature.</p>	<p>Put a thermometer on the control bulb. Read the temperature when the refrigeration unit cuts on. Read the temperature again when it cuts off. If the two temperatures are less than 16° F apart.</p>	<p>Turn the outside range screw clockwise.</p>
<p>7. The thermal overload switch opens after the compressor has been running a short time but before the temperature control switch cuts off.</p>	<p>Wait until the compressor stops then unplug the vender and open the temperature control box to see if the temperature control switch is closed. If it is,</p>	<p>Check the "Possible Causes" in the next 3 steps.</p>
<p>8. Not enough air is getting to the condenser.</p>	<p>See if there is anything around the outside of the vender. If there is,</p>	<p>Take it away.</p>
<p>9. The condenser is dirty</p>	<p>Look. Also feel the tube from the compressor to the condenser. If the tube is very hot or if you see dirt on the condenser.</p>	<p>Clean the condenser with either a vacuum cleaner, a brush or compressed air.</p>
<p>10. The condenser fan motor is burned out.</p>	<p>With the condenser fan motor leads correctly connected to the compressor motor terminals (see wiring diagram) see if the condenser fan runs when the compressor does. If it doesn't,</p>	<p>Put a new condenser fan motor in.</p>

**HOW TO CORRECT  
COMMON REFRIGERATION TROUBLES (Cont.)**

**THE COMPRESSOR RUNS BUT THE CANS/BOTTLES AREN'T COLD ENOUGH**

A POSSIBLE CAUSE IS	TO MAKE SURE	THIS IS WHAT TO DO
1. The evaporator fan is not working.	Look. If it is not working.	Check the "Possible Causes" in the next step. If it is working, skip the next step and go on to step 3 of this section.
2. The evaporator fan motor is burned out.	Remove black rubber junction block located on the fan motor bracket. Connect a 110V line to the evaporator fan motor leads. If the evaporator fan motor doesn't start,	Put a new evaporator fan motor in.
3. The temperature control cam is set too warm (high).	Turn the outside range screw of the temperature control clockwise to a colder setting and let the vender run overnight. If the cans/bottles get cold enough,  If the cans/bottles did not get colder,	Leave the temperature control at that setting.  Put a new temperature control in.
4. The evaporator is covered with frost and ice.	Look at it.	Defrost the evaporator then check the "Possible Causes" in the next 2 steps. If it isn't skip the next 2 steps and go to step 8 of this section.
5. The temperature control cam is set too cold and the evaporator is not defrosting.	Look at the evaporator for frost. If there is frost,  If the evaporator coil does not defrost on each cycle.  If, after the second setting, the coil still does not defrost,	Turn the inside range screw.  Turn the inside range screw.  Put a new temperature control in.

**HOW TO CORRECT  
COMMON REFRIGERATION TROUBLES (Cont.)**

**THE COMPRESSOR RUNS BUT THE CANS/BOTTLES AREN'T COLD ENOUGH (Cont.)**

A POSSIBLE CAUSE IS	TO MAKE SURE	THIS IS WHAT TO DO
6. The temperature control switch contacts stick closed.	If the unit runs all the time, and the evaporator builds up frost.	Put a new temperature control in.
7. The temperature control bulb sleeve is touching the evaporator.	Look at it. If it is touching the evaporator tube.	Bend the bracket so that there will be space between the bulb sleeve and the evaporator tube.
8. The control bulb is not in the sleeve (holder).	Look. If it is not.	Put the bulb in the sleeve (holder).
9. The temperature control bellows is not working.	Warm the temperature control bulb with your hand for about one minute. If the temperature control switch doesn't close,	Put a new temperature control in.
10. The refrigerant tubing is kinked or bent sharply.	Look, if it is,  If this does not help and no other cause can be found for the trouble.	Try to get the kink out.  Put some new refrigerant tubing in.
11. There isn't enough refrigerant in the refrigeration system or the capillary tube is partly plugged.	Let the vender run at least 15 minutes and then see if the evaporator is frosted all over. If it isn't,	Try to blow the plug out of the capillary tube, evacuate the system and then put a new charge of gas in the refrigeration unit.
12. The condenser isn't getting enough air.	See if there is anything around the outside of the vender to keep the air out. If there is,	Take it away.
13. The condenser is dirty.	Look. Also feel the tube from the compressor to the condenser. If the tube is very hot, or if you see dirt,	Clean the condenser with either a vacuum cleaner, a brush or compressed air.

**HOW TO CORRECT  
COMMON REFRIGERATION TROUBLES (Cont.)**

**THE COMPRESSOR RUNS BUT THE CANS/BOTTLES AREN'T COLD ENOUGH (Cont.)**

A POSSIBLE CAUSE IS	TO MAKE SURE	THIS IS WHAT TO DO
<p>14. The condenser fan motor is burned out.</p>	<p>With the condenser fan motor leads correctly connected to the compressor terminal, see if the condenser fan runs when the compressor does. If it doesn't,</p>	<p>Put a new condenser fan motor in.</p>
<p>15. The thermal overload switch is starting and stopping the compressor.</p>	<p>Unplug the vender for at least 15 minutes, then plug it in again. Be sure the temperature control switch is closed. (Warm the temperature control bulb with your hand to close it.) If the compressor motor cuts off then on, then off while the temperature control switch stays closed.</p>	<p>Check the "Possible Causes" in steps 16 and 17.</p>
<p>16. The voltage at the vender is either too high or too low.</p>	<p>1. When an extension is not used on the supply cord: While the compressor is running put one prod of a volt meter on terminal (S) of the starting relay and the other prod on terminal (L) of the starting relay. If the voltage is not between 105V and 126V,</p> <p>2. When an extension is used on the supply cord: Put a double socket on the plug end of the extension and plug it into the outlet. While the compressor is running, put the prods of a volt meter on terminal (S) of the starting relay and the other prod on terminal (L) of the starting relay. If the voltage is not between 105V and 126V.</p>	<p>Have the person in charge of the vender tell the power company so they can take care of it</p> <p>Have the person in charge of the vender tell the power company so they can take care of it.</p>

**HOW TO CORRECT  
COMMON REFRIGERATION TROUBLES (Cont.)**

**THE COMPRESSOR RUNS BUT THE CANS/BOTTLES AREN'T COLD ENOUGH (Cont.)**

A POSSIBLE CAUSE IS	TO MAKE SURE	THIS IS WHAT TO DO
<p>17. The starting relay contacts are sticking closed.</p>	<p>Look and see. If they are,</p>	<p>Put a new starting relay in.</p>
<b>THE CANS/BOTTLES ARE TOO COLD</b>		
<p>1. The temperature control bulb is not in its tube.</p>	<p>Look and see. If it isn't,</p>	<p>Put the bulb in its tube.</p>
<p>2. The temperature control cam is set too cold.</p>	<p>Turn the outside range screw of the temperature control cam counter-clockwise to a warmer setting and let the vender run over night. If the cans bottles get cold enough but not too cold, unplug the vender and let the evaporator fan come to a stop.</p>	<p>Leave the temperature control cam at that setting</p>
<p>3. The temperature control switch is stuck closed.</p>	<p>Then block the fan blade so it can't turn. Remove the temperature control bulb from its tube and touch it to the evaporator tube. Plug the vender back in and let the compressor run until it cuts off, but not more than 30 minutes. If the vender has not cut off.</p>	
<b>THE REFRIGERATION UNIT IS NOISY</b>		
<p>1. The refrigerant lines rattle.</p>	<p>Hold them between your fingers. If the rattle stops.</p>	<p>Bend them gently away from whatever they are hitting.</p>

**HOW TO CORRECT  
COMMON REFRIGERATION TROUBLES (Cont.)  
THE COMPRESSOR MOTOR NEVER STOPS RUNNING**

A POSSIBLE CAUSE IS	TO MAKE SURE	THIS IS WHAT TO DO
<p>1. The temperature control switch is stuck closed.</p> <p>2. The compressor has a broken valve or no refrigerant in the refrigeration system.</p>	<p>Turn the inside range screw cam and the range screw to their warmest settings. Let the venter run overnight, or until it stops, If the compressor motor doesn't stop running.</p> <p>The tube from the compressor to the condenser is not warm and the evaporator is not cold,</p> <p>If this does not help,</p>	<p>Put a new temperature control in.</p> <p>Put a new charge of refrigeration in the refrigeration unit.</p> <p>Put a new motor compressor in the refrigeration unit.</p>



HOW TO CORRECT  
COMMON REFRIGERATION TROUBLES (Cont.)

- WIRING DIAGRAM -

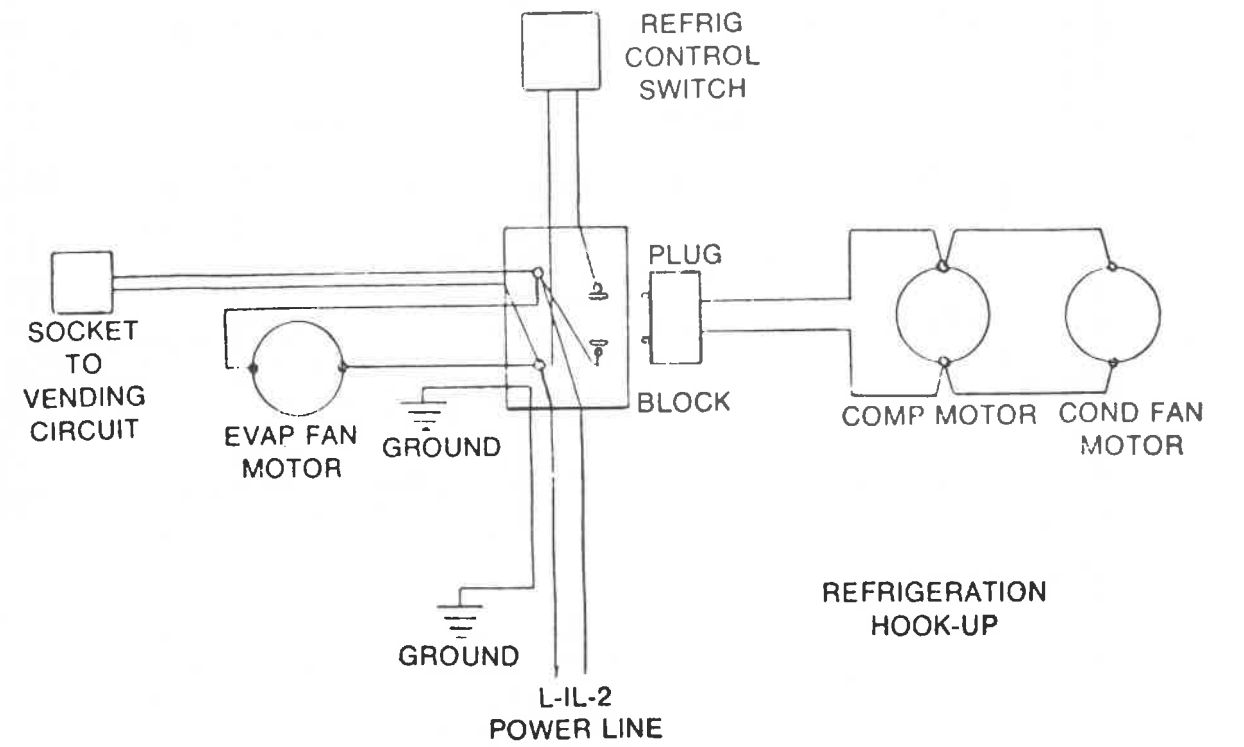
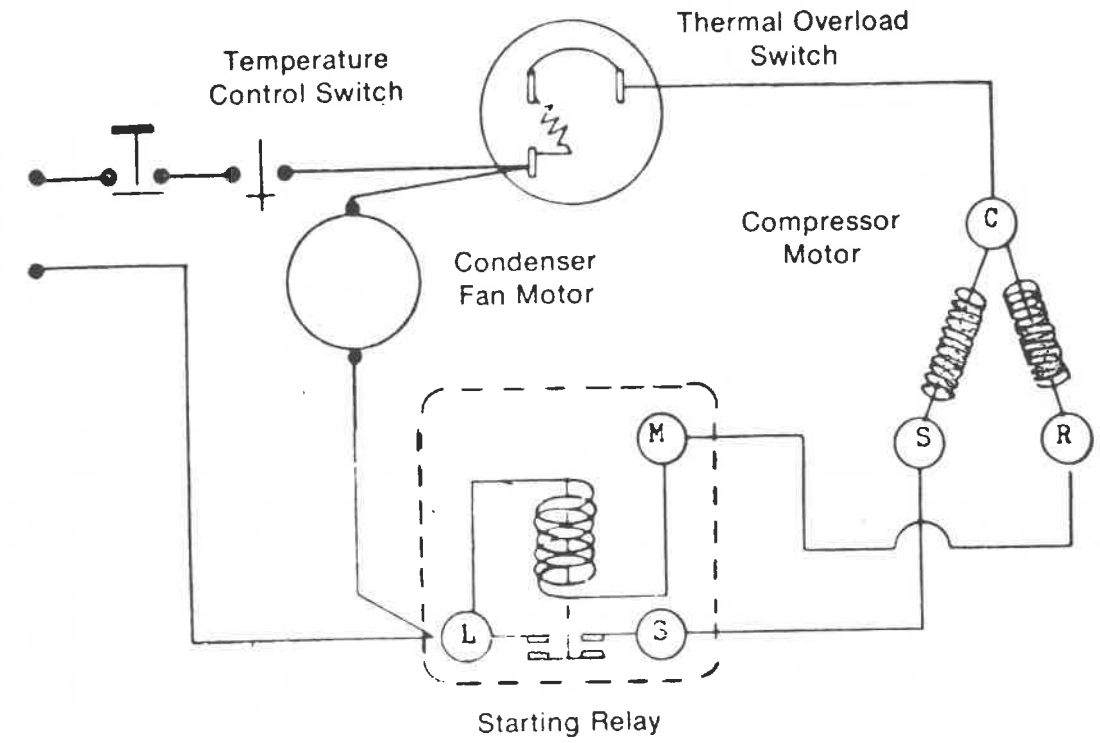

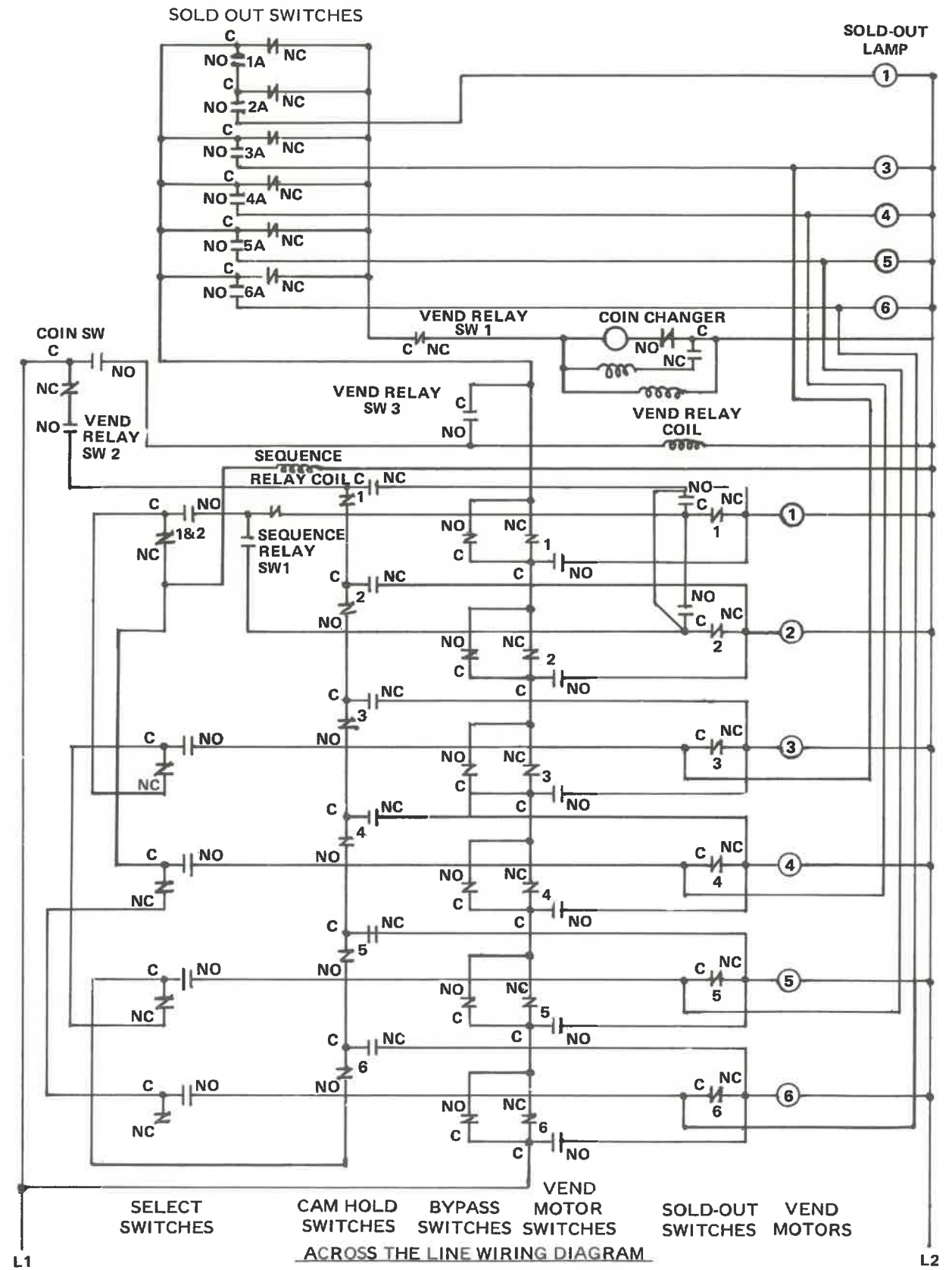

ACROSS THE LINE WIRING DIAGRAM

6 COLUMN ADAPTIBLES, 1 RELAY, LOCKOUT SEQUENCING 1 & 2

ALL SWITCHES SHOWN IN POSITION WHEN VENDOR IS READY TO ACCEPT COINS

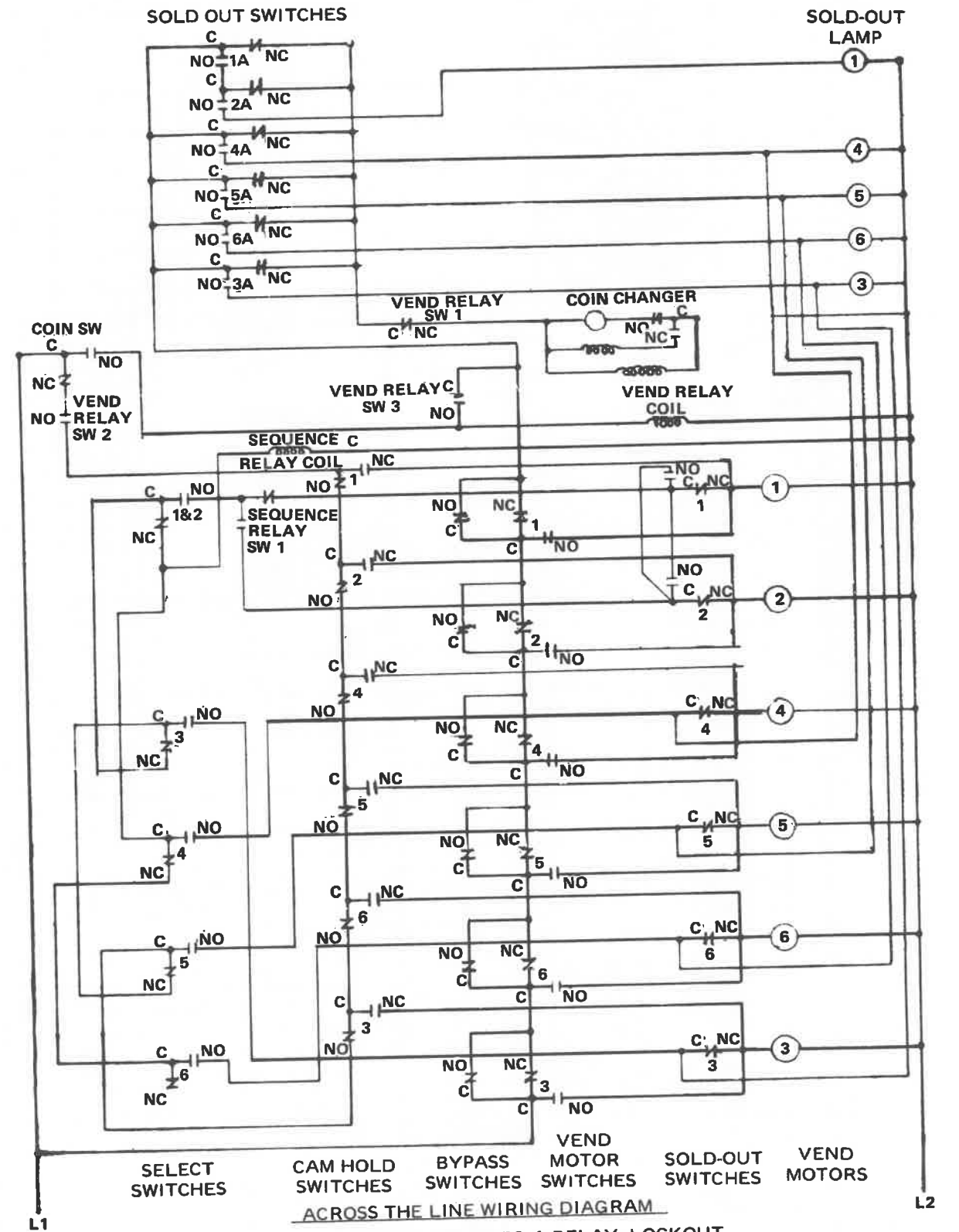

ACROSS THE LINE WIRING DIAGRAM  
 6 COLUMN DUAL ADAPTABLES, 1 RELAY, LOCKOUT SEQUENCING 1 & 2  
 ALL SWITCHES SHOWN IN POSITION WHEN VENDOR IS READY TO ACCEPT COINS

C7290.05  
 PWJ 12/10/79

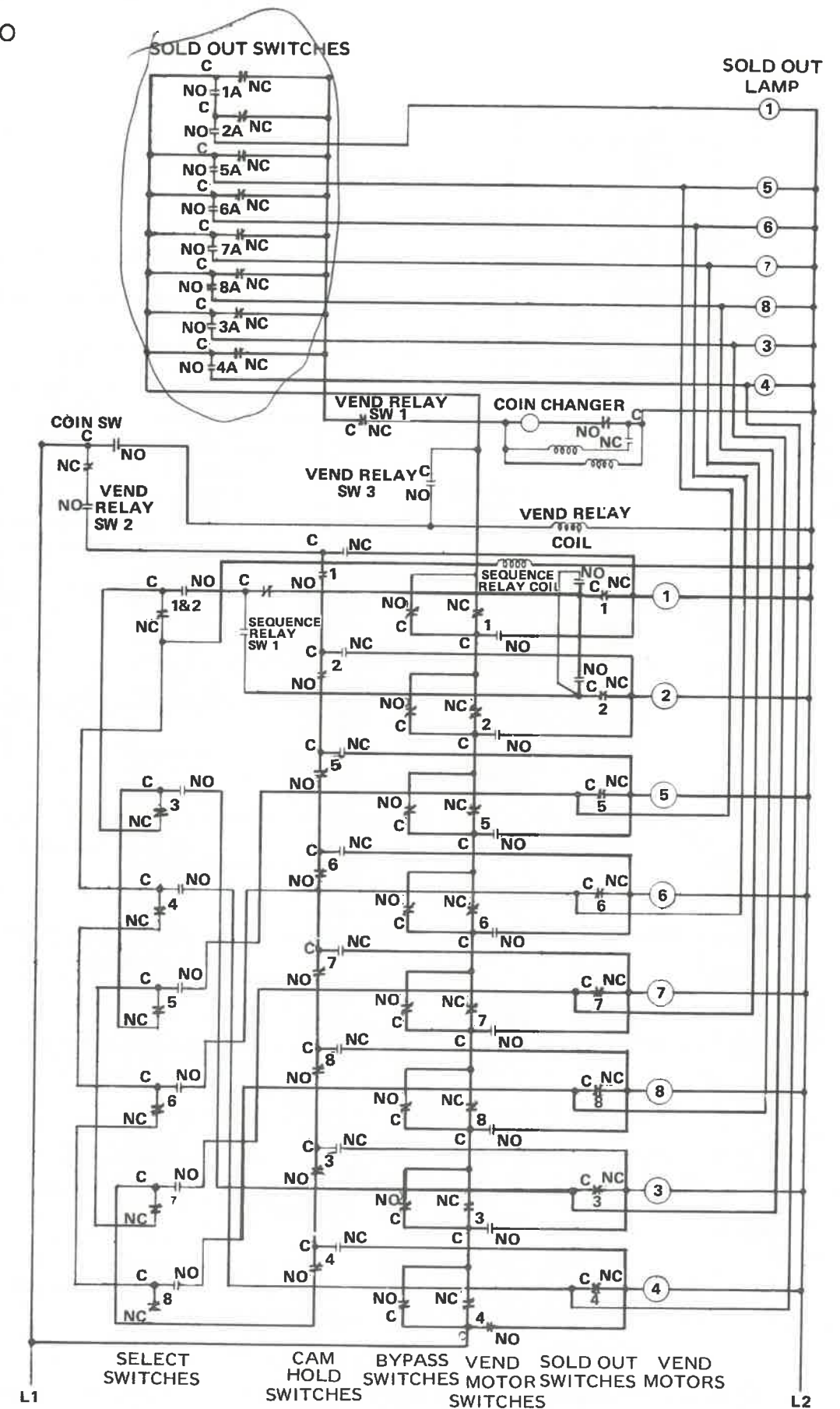

ACROSS THE LINE WIRING DIAGRAM

8 COLUMN ADAPTIBLES, 1 RELAY, LOCKOUT, SEQUENCING 1 & 2  
 ALL SWITCHES SHOWN IN POSITION WHEN VENDER IS READY TO ACCEPT COINS

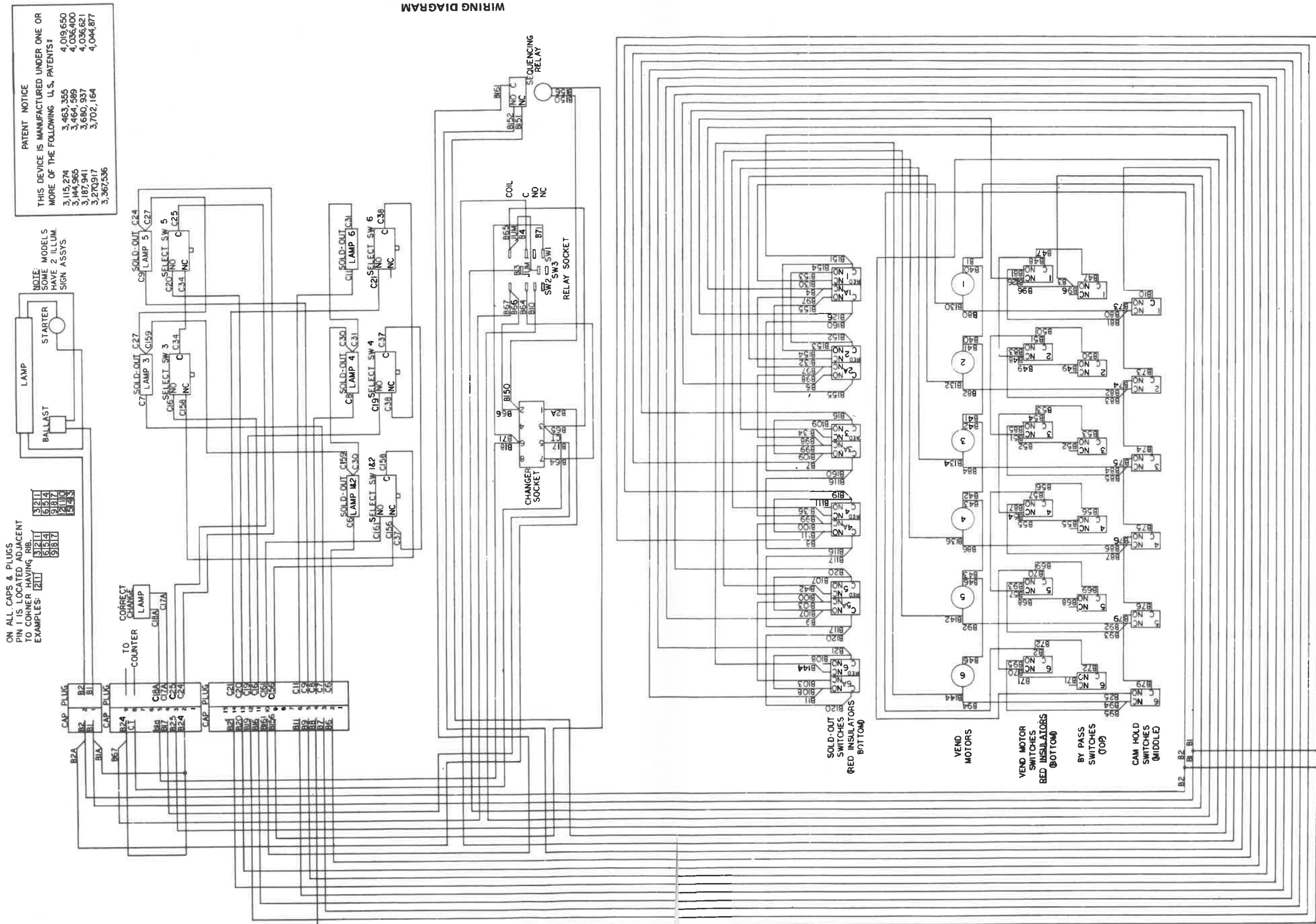

ON ALL CAPS & PLUGS  
PIN 1 IS LOCATED ADJACENT  
TO CORNER HAVING RIB.  
EXAMPLES: 

3	2	1
5	4	3
9	8	7
12	11	10
15	14	13

PATENT NOTICE  
THIS DEVICE IS MANUFACTURED UNDER ONE OR  
MORE OF THE FOLLOWING U.S. PATENTS:  
3,115,274  
3,144,965  
3,187,941  
3,270,917  
3,367,536  
3,463,355  
3,464,589  
3,680,937  
3,702,164  
4,019,650  
4,036,400  
4,036,621  
4,044,877

NOTE:  
SOME MODELS  
HAVE 2 ILLUM.  
SIGN ASSYS.



3	2	1
5	4	3
9	8	7
12	11	10
15	14	13

33

•  
•

33

•  
•

33

WIRING DIAGRAM  
6 COLUMN DUAL ADAPTIBLES  
SEQUENCING 1 & 2  
F803,812,370,01

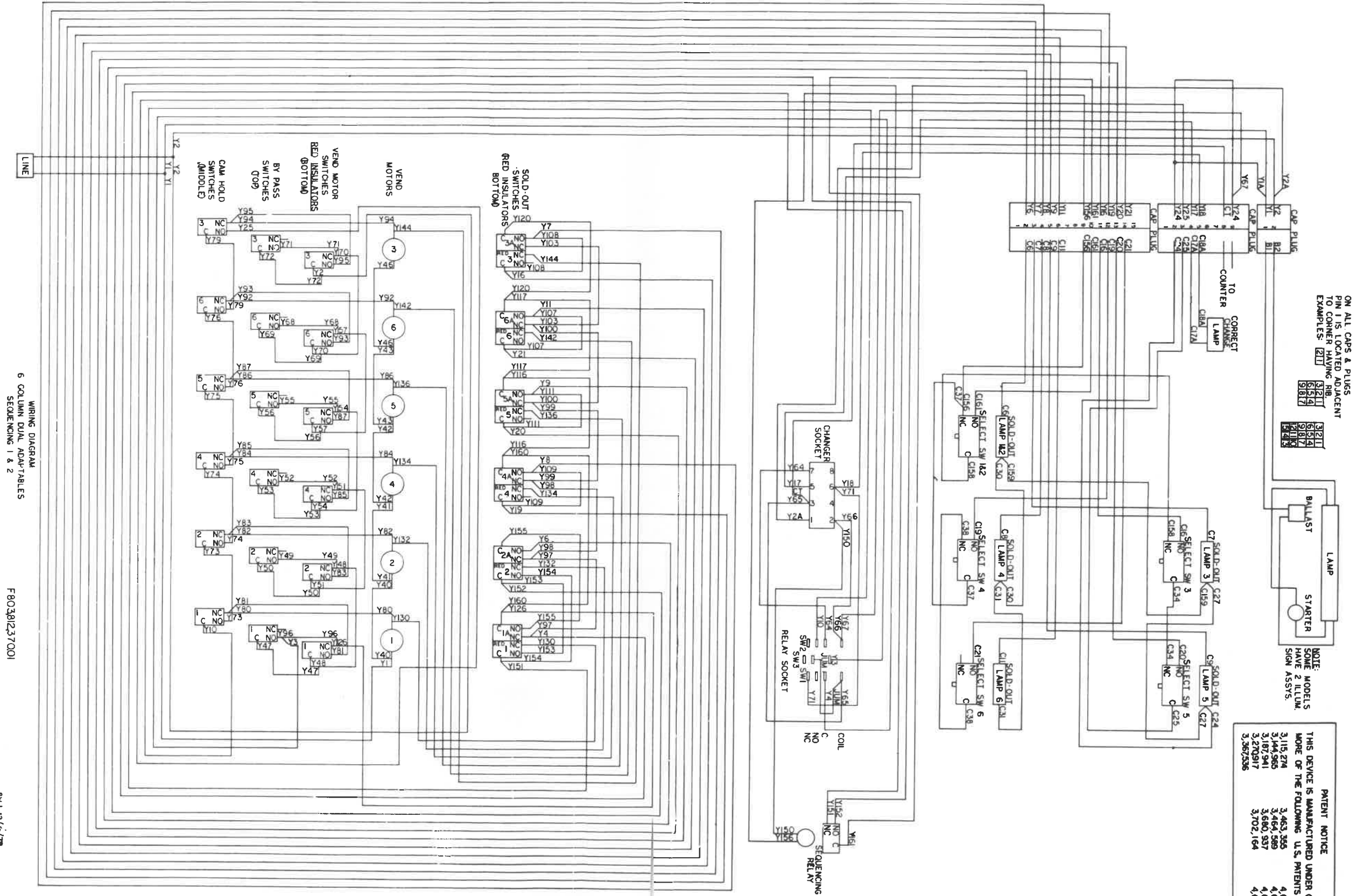

WIRING DIAGRAM  
6 COLUMN DUAL ADAPTIBLES  
SEQUENCING 1 & 2

F803,812,370,01

PAJ 12/67mm

ON ALL CAPS & PLUGS  
PIN 1 IS LOCATED ADJACENT  
TO CORNER HAVING RB.  
EXAMPLES: 211 31211 61514 91817 32111 61514 91817 32111 61514 91817

NOTE: MODELS  
HAVE 2 ILLUM.  
SIGN ASSYS.

PATENT NOTICE  
THIS DEVICE IS MANUFACTURED UNDER ONE OR  
MORE OF THE FOLLOWING U.S. PATENTS:  
3,115,274 3,463,365 4,019,650  
3,144,966 3,464,589 4,036,400  
3,187,941 3,680,937 4,036,621  
3,270,917 3,702,164 4,044,877  
3,367,536

WIRING DIAGRAM  
6 COLUMN ADAPTIBLES  
SEQUENCING 1 & 2

U U

.  
.

U U

.  
.

U U



WIRING DIAGRAM  
8 COLUMN ADAPTIBLES  
SEQUENCING 1 & 2  
F80381215001

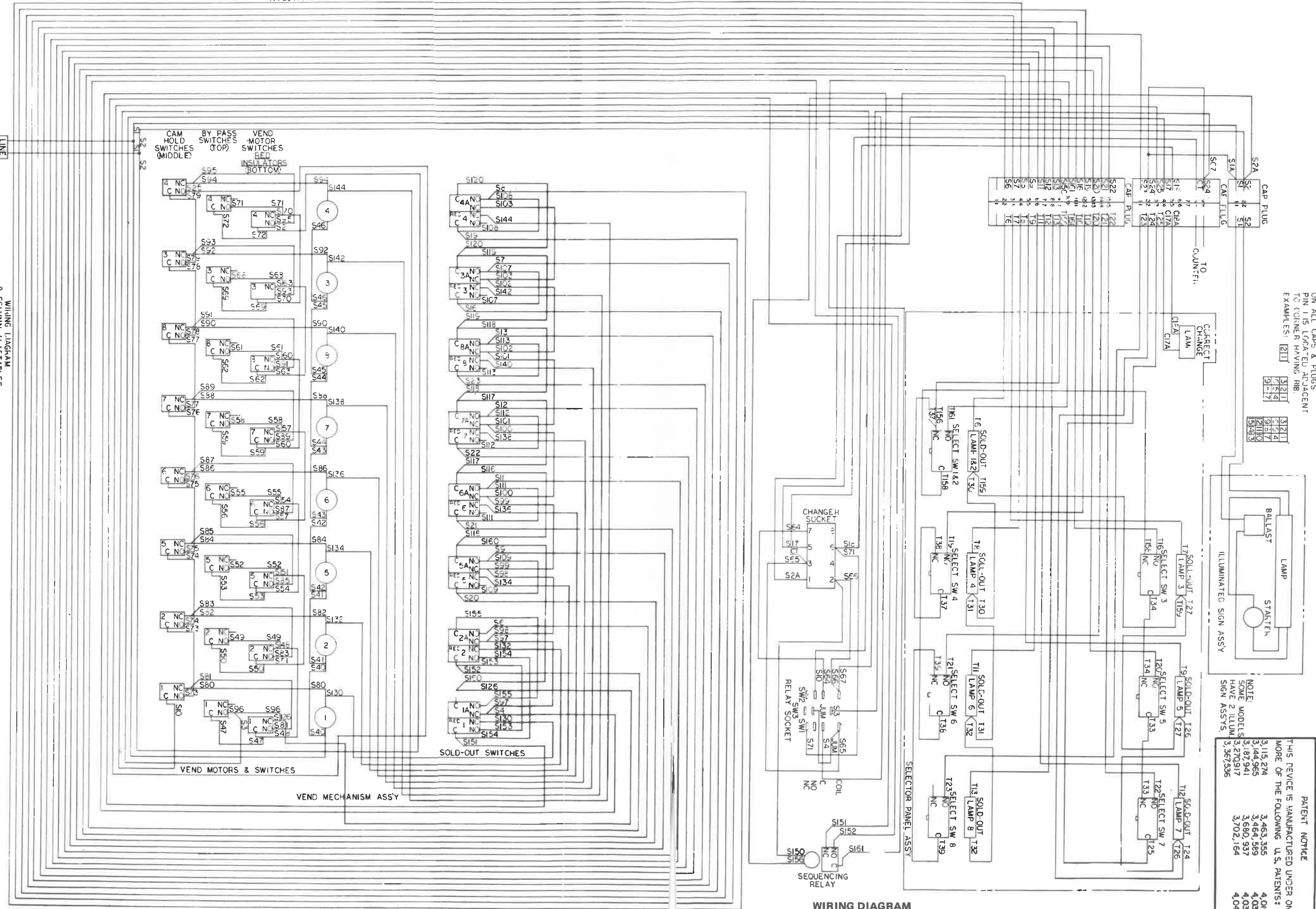

UN ALL CAPS & PLUGS  
PIN 1 IS LOCATED ADJACENT  
TO CORNER HAVING RB:  
EXAMPLES: [21] [31] [41] [51] [61] [71] [81] [91] [101] [111] [121] [131] [141] [151]

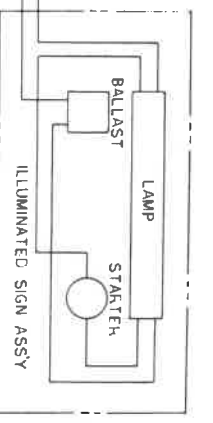

NOTE:  
SOME MODELS  
HAVE 2 ILLUM  
SIGN ASSYS.

PATENT NOTICE

THIS DEVICE IS MANUFACTURED UNDER ONE OR MORE OF THE FOLLOWING U.S. PATENTS:

3,115,274	3,463,355	4,019,653
3,144,965	3,464,359	4,026,403
3,187,941	3,680,937	4,036,621
3,270,917	3,702,164	4,044,877
3,367,536		

WIRING DIAGRAM  
8 COLUMN ADAPTIBLES  
SEQUENCING 1 & 2

U U

.

U U

.

U U

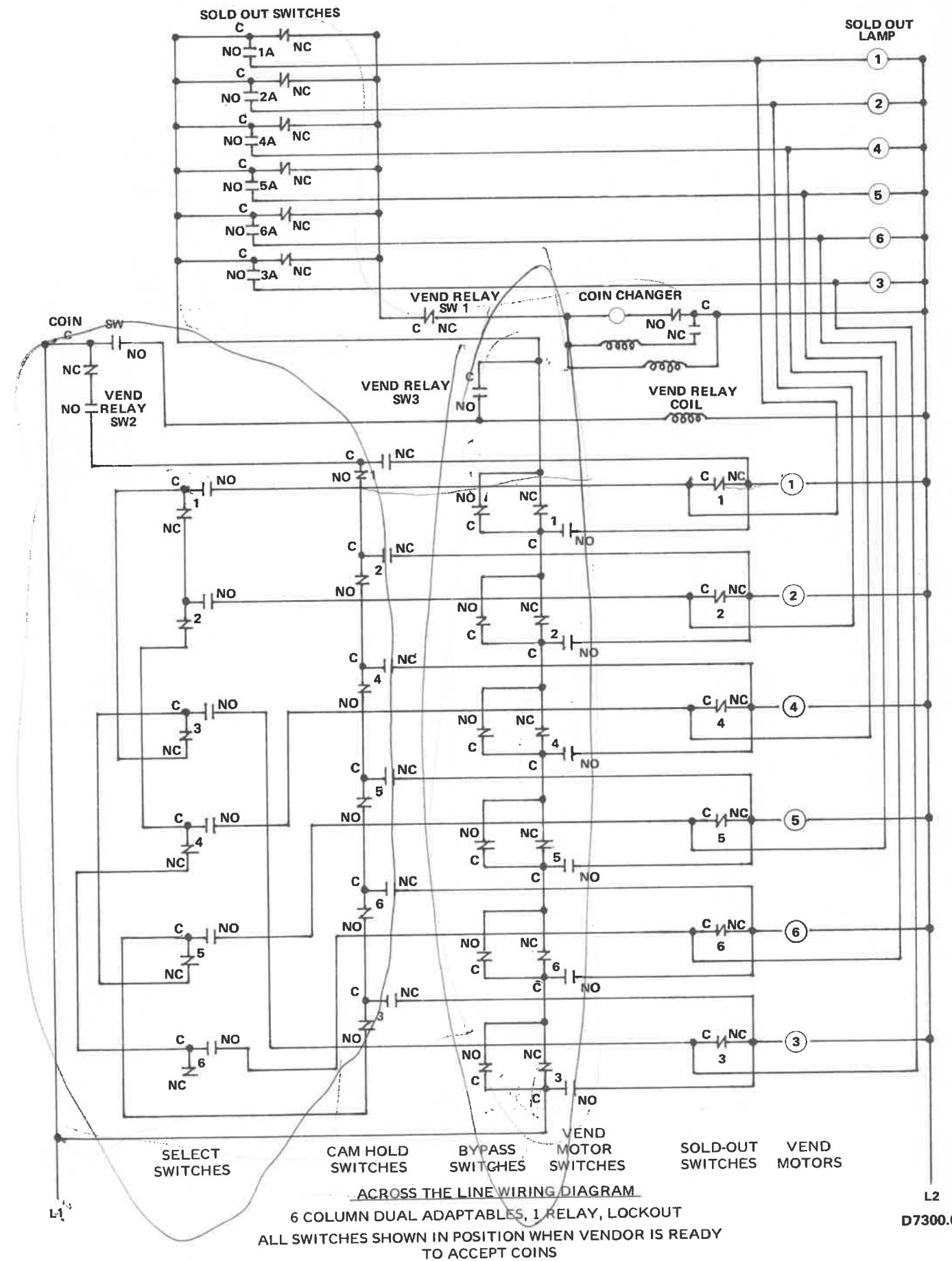

ACROSS THE LINE WIRING DIAGRAM  
 6 COLUMN DUAL ADAPTIBLES, 1 RELAY, LOCKOUT  
 ALL SWITCHES SHOWN IN POSITION WHEN VENDOR IS READY  
 TO ACCEPT COINS

L2  
 D7300.05

DIXIE-NARCO

UN ALL CAPS & PLUGS  
 PIN 1 IS LOGIC ED ADJACENT  
 TO CORNER HAVING RIB  
 EXAMPLES: 211

31211  
 31514  
 31817  
 32110  
 32413

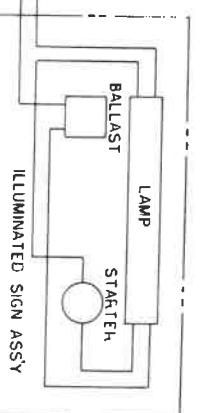

NOTE:  
 SOME MODELS  
 HAVE 2 ILLUM  
 SIGN ASSYS.

PATENT NOTICE	
THIS DEVICE IS MANUFACTURED UNDER ONE OR MORE OF THE FOLLOWING U.S. PATENTS:	
3,115,274	3,463,365
3,144,965	3,464,589
3,187,941	3,680,937
3,270,917	3,702,164
3,267,536	4,019,653
	4,036,403
	4,036,621
	4,044,877

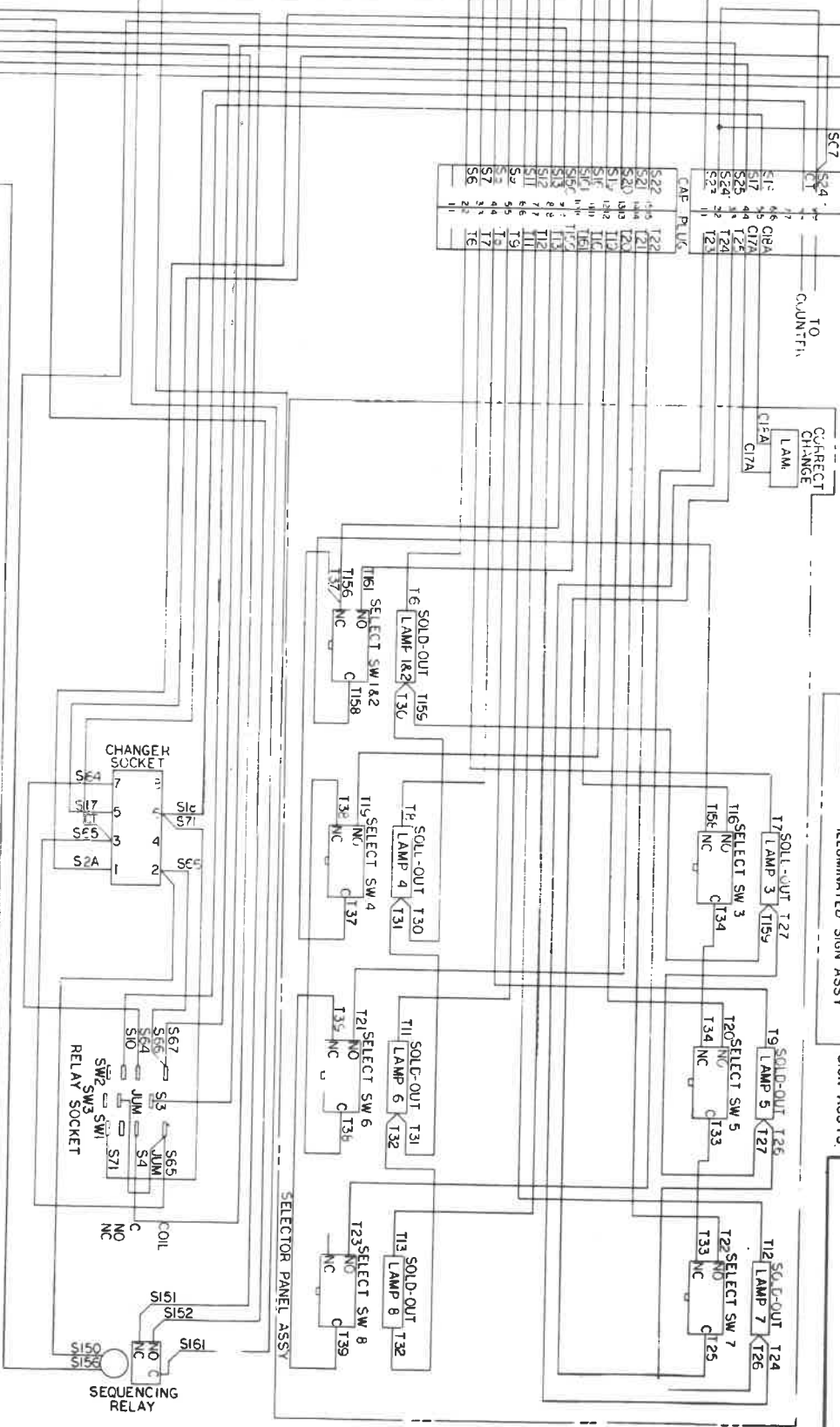

**WIRING DIAGRAM  
 8 COLUMN ADAPTABLES  
 SEQUENCING 1 & 2**

F803,812,150.01



**PATENT NOTICE**  
 THIS DEVICE IS MANUFACTURED UNDER ONE OR MORE OF THE FOLLOWING U.S. PATENTS:  
 3,115,274 3,463,355 4,019,660  
 3,144,965 3,484,589 4,058,400  
 3,187,941 3,680,937 4,096,621  
 3,270,917 3,702,164 4,044,877  
 3,367,536

**NOTE:**  
 SOME MODELS  
 HAVE 2 ILLUM.  
 SIGN ASSYS.

ON ALL CAPS & PLUGS  
 PIN 1 IS LOCATED ADJACENT  
 TO CORNER HAVING  
 EXAMPLES: 

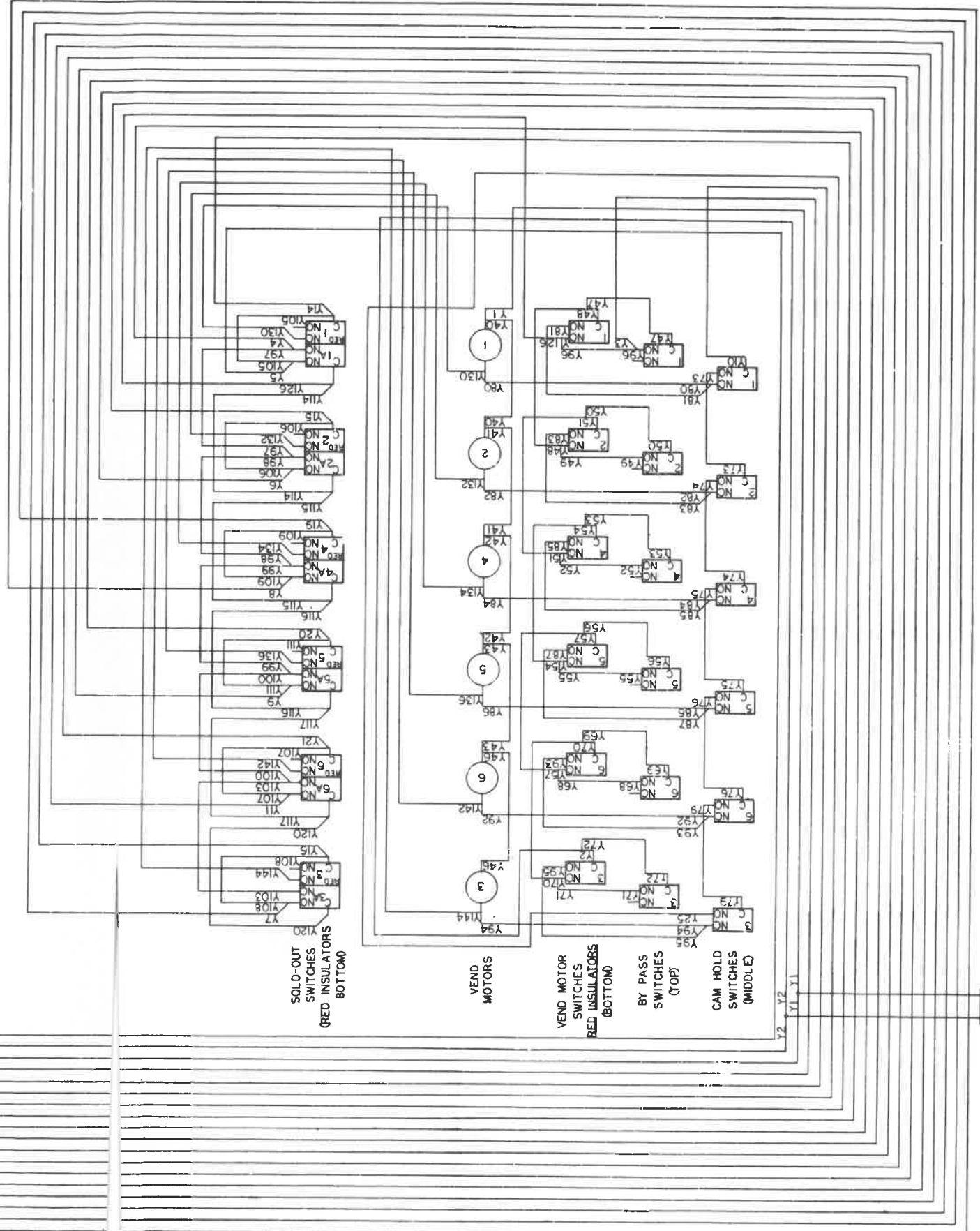
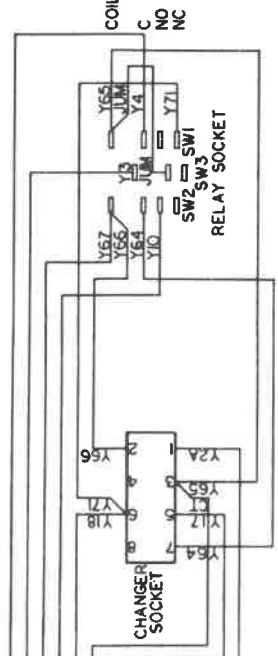
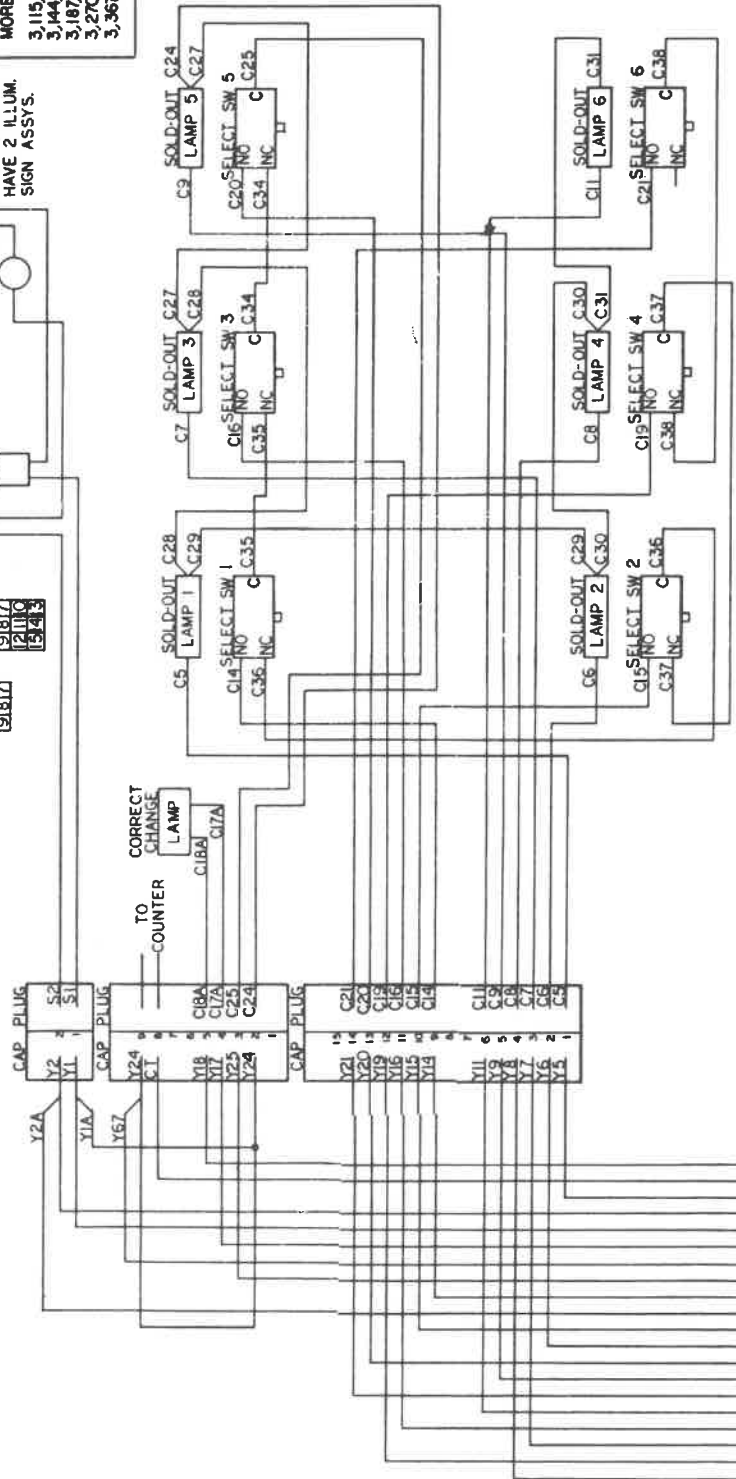





ON ALL CAPS & PLUGS  
PIN 1 IS LOCATED ADJACENT  
TO CORNER HAVING RIB.  
EX-EMPLES

311	312	313	314	315
316	317	318	319	320
321	322	323	324	325

PATENT NOTICE  
THIS DEVICE IS MANUFACTURED UNDER ONE OR  
MORE OF THE FOLLOWING U. S. PATENTS:

3,115,274	3,463,355	4,019,650
3,144,965	3,464,589	4,036,400
3,187,941	3,680,957	4,036,621
3,702,164	3,702,164	4,044,877

NOTE: MODULIS 3-270317  
SCAMP HAVE 2 ILLUMI. 3-367536  
JCAN A-355

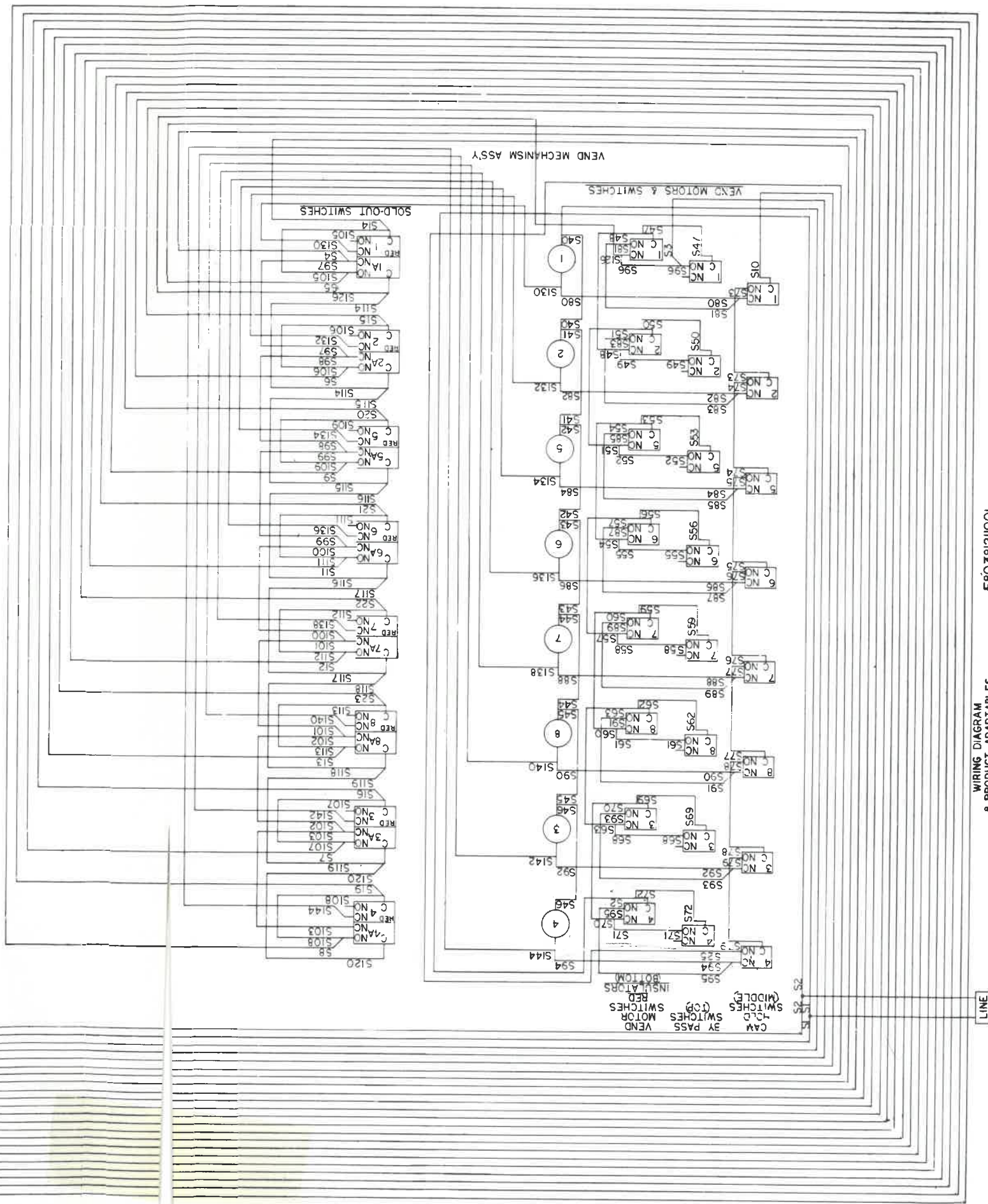
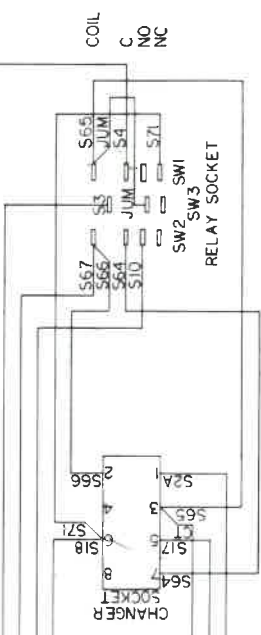
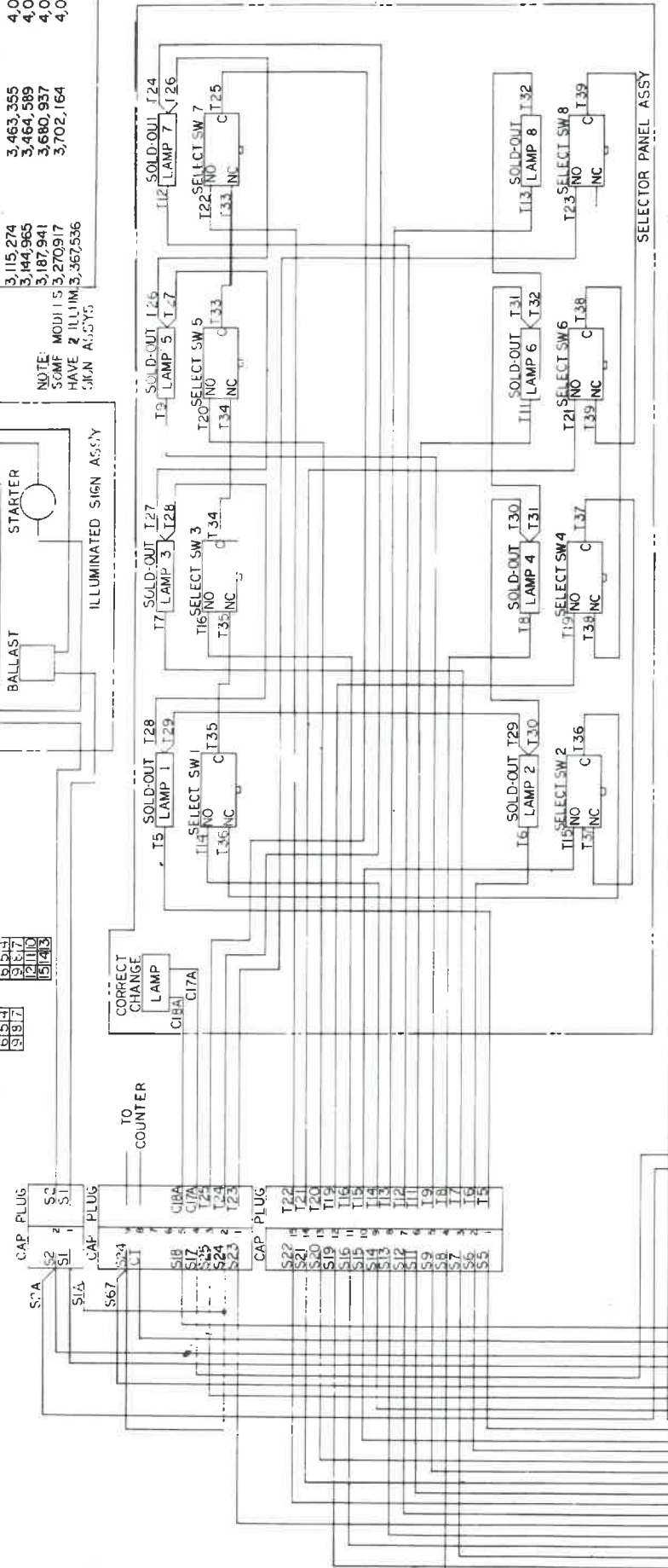
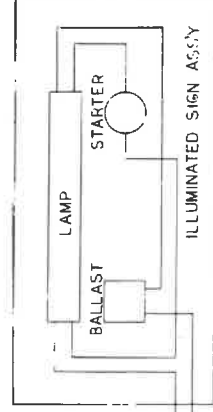

00

.

.

00

.

.

00

ON ALL CAPS & PLUGS  
PIN 1 IS LOCATED ADJACENT  
TO CORNER HAVING RIB.  
EY-MPLES

- 3211
- 3212
- 3213
- 3214
- 3215
- 3216
- 3217
- 3218
- 3219
- 3220
- 3221
- 3222
- 3223
- 3224
- 3225

PATENT NOTICE  
THIS DEVICE IS MANUFACTURED UNDER ONE OR  
MORE OF THE FOLLOWING U.S. PATENTS:

3,115,274	3,463,355	4,019,650
3,144,965	3,464,589	4,036,400
3,187,941	3,680,937	4,036,621
3,270,917	3,702,164	4,044,877
3,567,536		

NOTE: MODIF. S. 270917  
HAVE 2 ILLUM. SIGN ASSY.  
SIGN ASSYS.

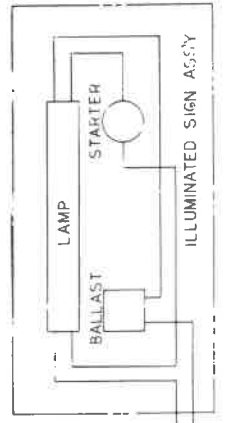

CORRECT  
CHANGE  
LAMP

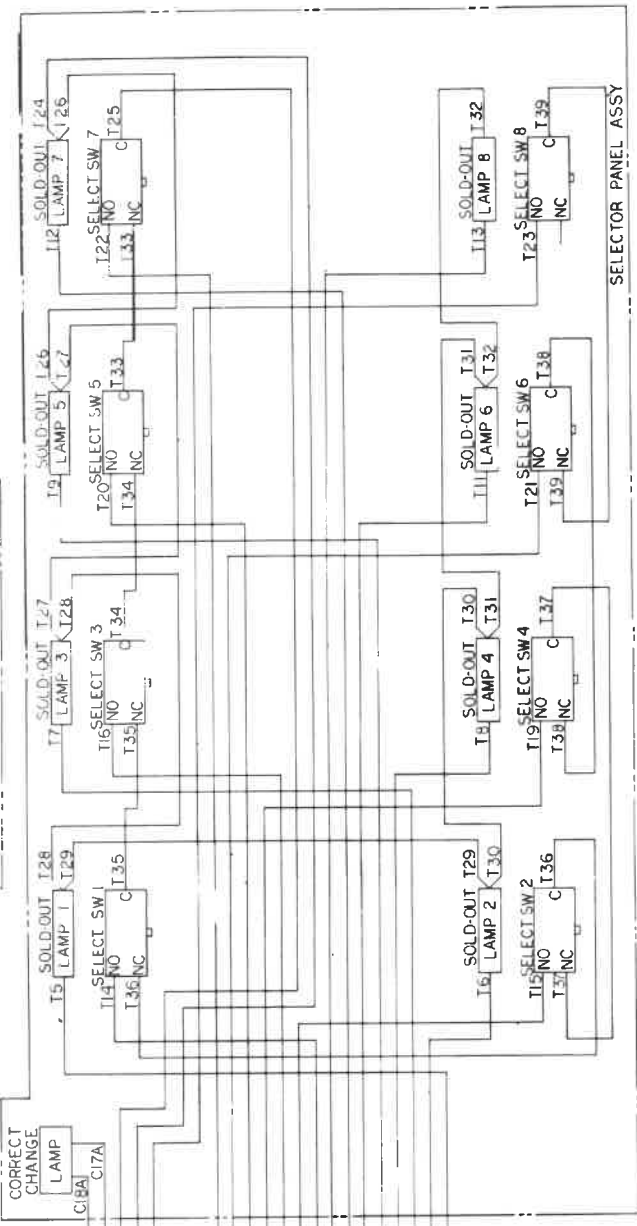

SELECTOR PANEL ASSY

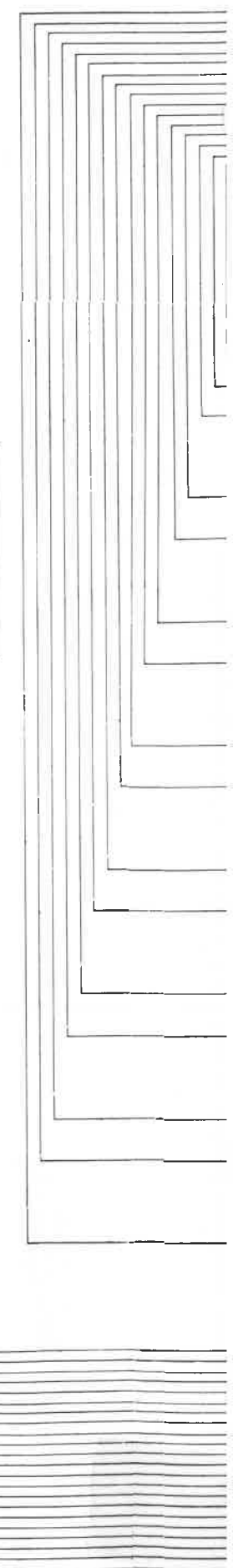
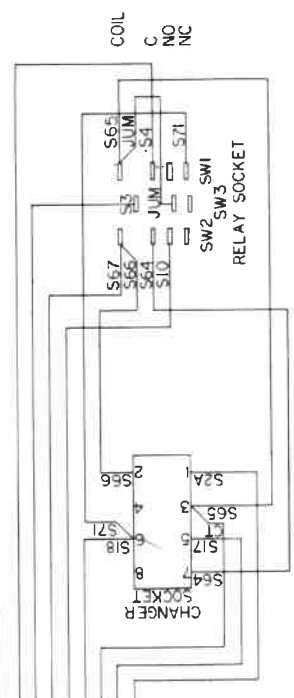

00

.

.

00

.

.

00

w.o.p.w. 8/2/77

WIRING DIAGRAM

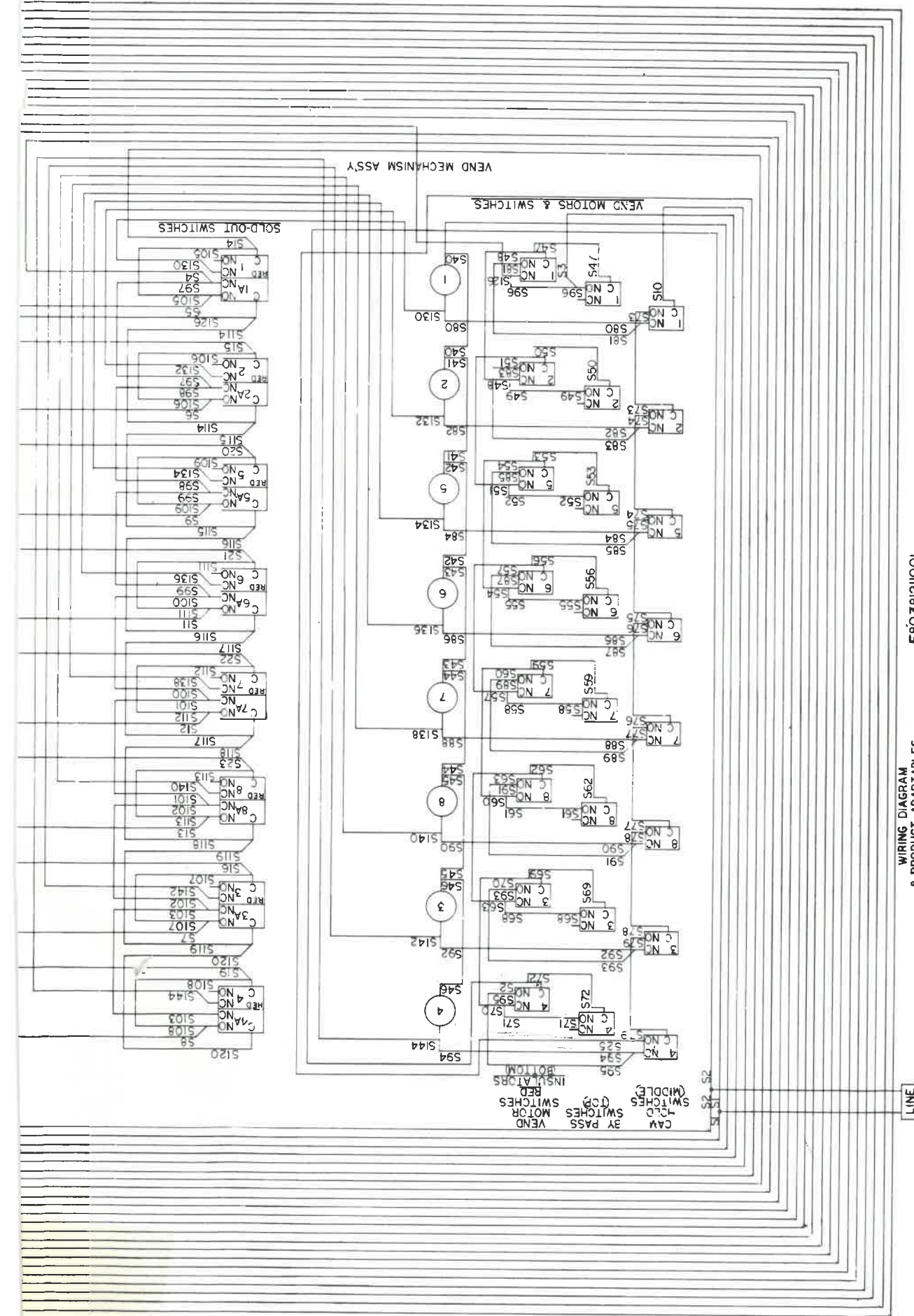

LINE

WIRING DIAGRAM  
8 PRODUCT ADAPTABLES

F8039121001



**PARTS LIST  
CONTENTS**

MAIN DOOR .....75  
 WELDED ASSEMBLY MAIN DOOR .....77  
 INTERIOR MAIN DOOR ASSEMBLY.....79  
 LAMP PANEL DOOR ASSEMBLY.....83  
 CONTROL PANEL ASSEMBLY.....87  
 INNER DOOR ASSEMBLY .....89  
 WIRING HARNESS .....91  
 HINGES AND HANDLES.....93  
 CABINET AND VEND MECHANISM .....95  
 REFRIGERATION SYSTEM .....107

**PARTS LIST – MAGNUM  
CONTENTS**

MAIN DOOR ASSEMBLY – MAGNUM.....109  
 WELDED ASSEMBLY MAIN DOOR – MAGNUM .....111  
 INNER DOOR ASSEMBLY – MAGNUM.....113  
 CONTROL PANEL ASSEMBLY – MAGNUM.....115  
 SIGN AND DELIVERY PORT AREA – MAGNUM.....119  
 PROTECTIVE PLATE AND INTERIOR MAIN DOOR PARTS – MAGNUM .....121  
 FLUORESCENT LAMPS FOR MAGNUM SERIALIZED 2752 AND HIGHER.....123  
 FLUORESCENT LAMPS FOR MAGNUM SERIALIZED 2679 THRU 2751 .....125  
 WIRING HARNESS .....91  
 HINGES AND HANDLE.....93  
 CABINET AND VEND MECHANISM .....95  
 REFRIGERATION SYSTEM .....107

**PARTS LIST – CENTURY II  
CONTENTS**

MAIN DOOR ASSEMBLY – CENTURY II .....127  
 MAIN DOOR W/A – CENTURY II .....129  
 MAIN INTERIOR PARTS – CENTURY II .....131  
 MAIN DOOR PARTS ACCESS AREA – CENTURY II .....133  
 MAIN DOOR PARTS – ALL CENTURY II.....135  
 WIRING HARNESS .....91  
 HINGES AND HANDLE.....93  
 CABINET & VEND MECHANISM .....95  
 REFRIGERATION SYSTEM .....107

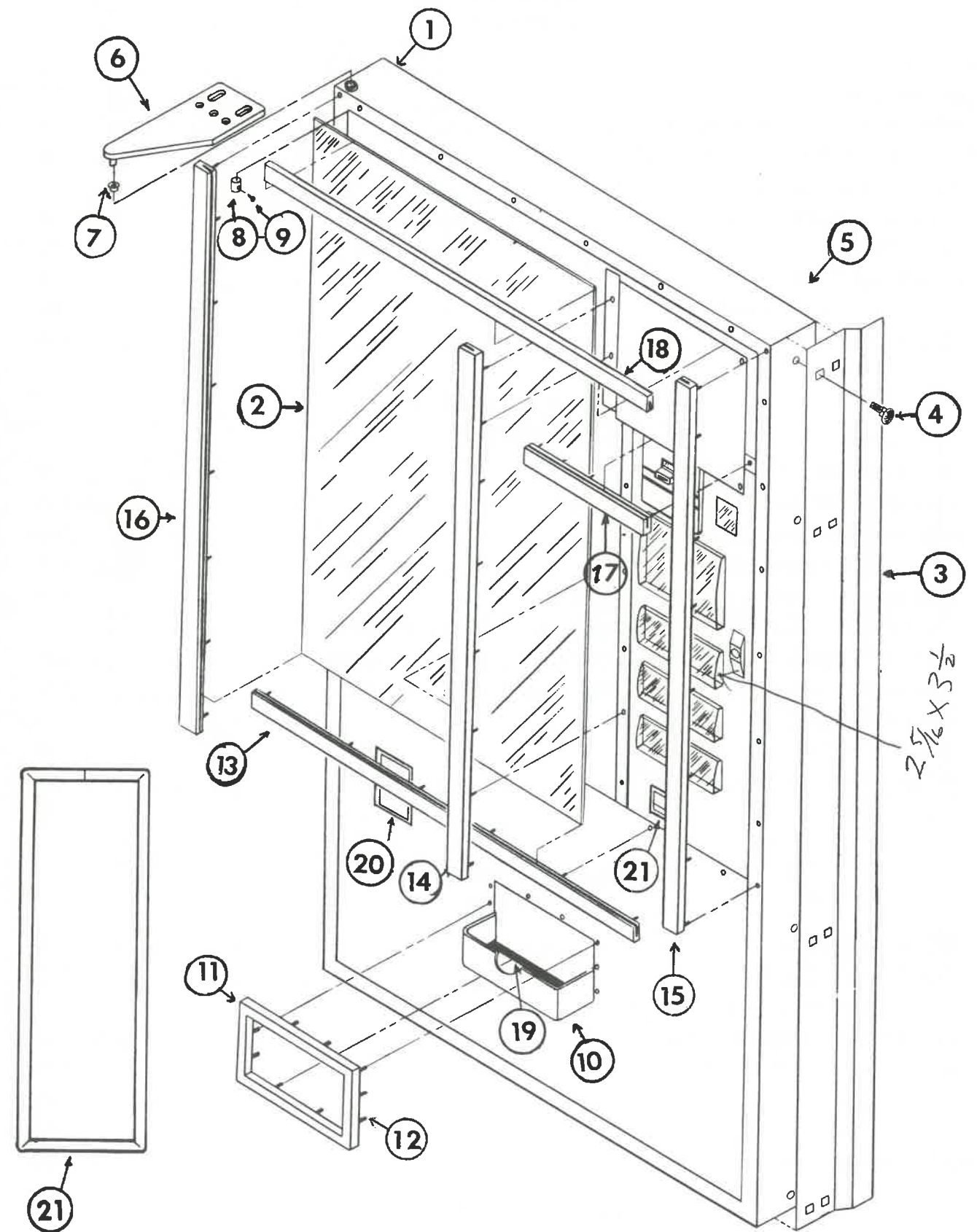





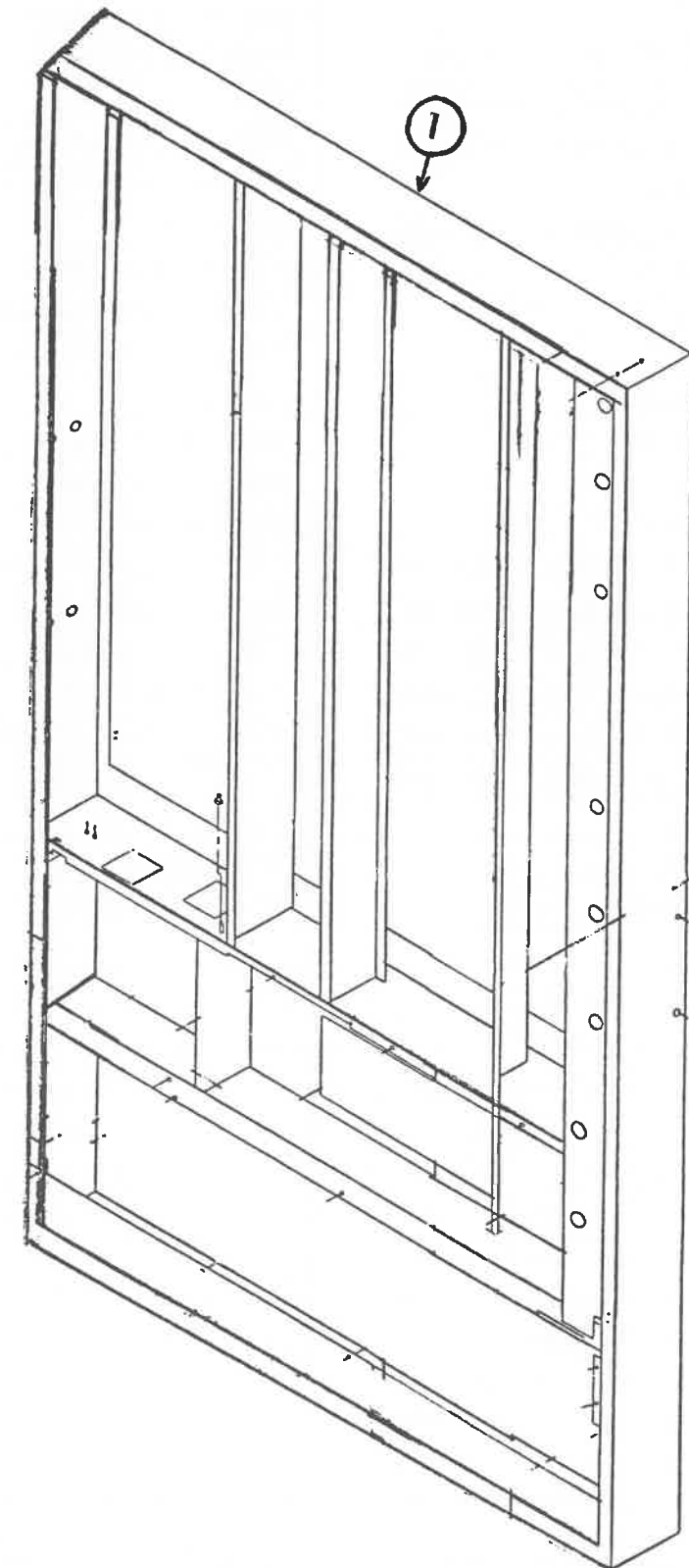

**WELDED ASSEMBLY MAIN DOOR**  
**(All DNCB Venders)**

Item No.	PART NUMBER	PART NAME AND DESCRIPTION
1	Indicate Model #, Serial #, & Trademark	Main Door W/A (only) with Vinyl installed

WHEN ORDERING PARTS INDICATE MODEL # AND SERIAL # OF VENDER.  
ALL PRICES ARE SUBJECT TO CHANGE WITHOUT NOTICE.

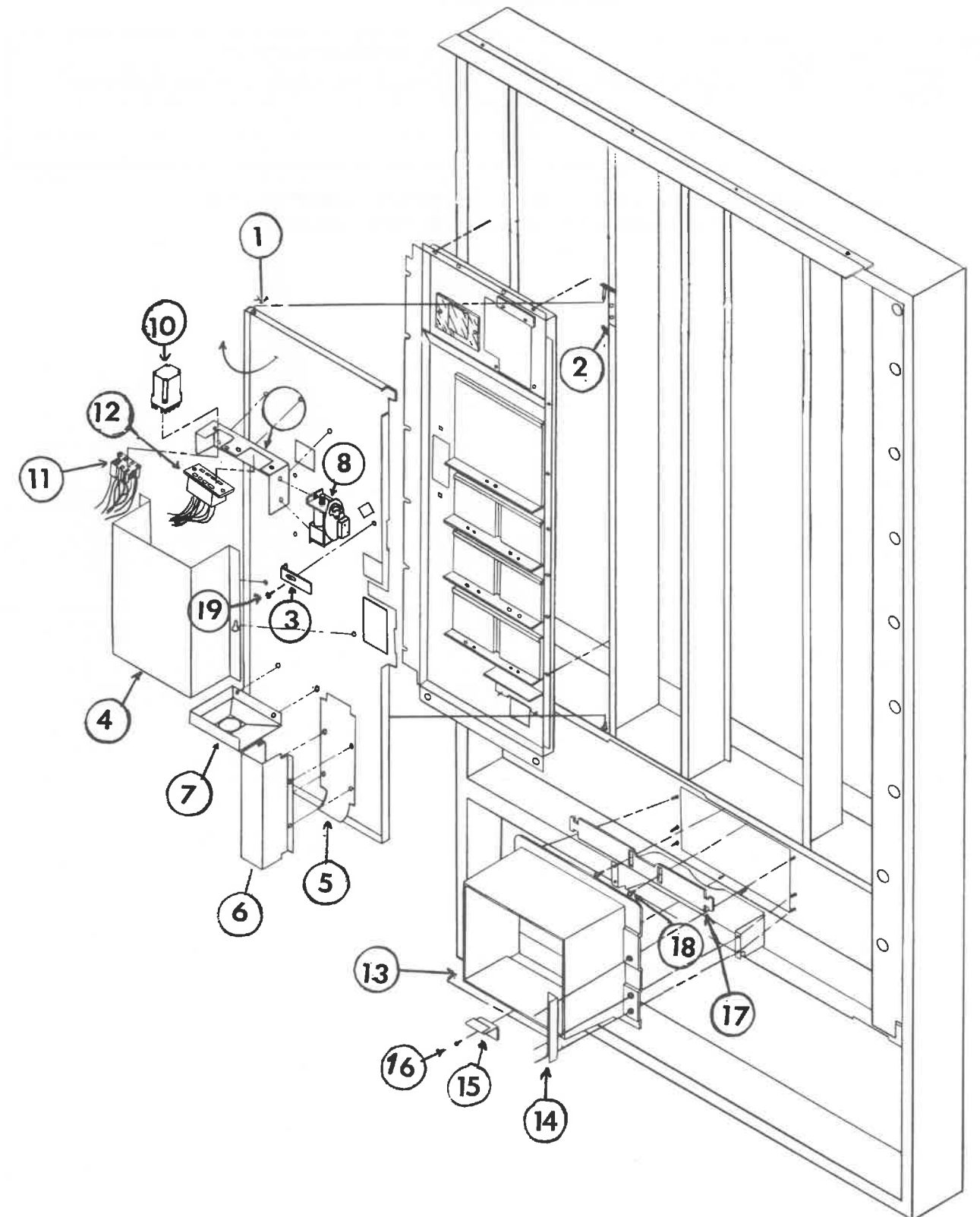

**MAIN DOOR ASSEMBLY**  
 (Interior - All DNCB Venders)

Item No.	PART NUMBER	PART NAME AND DESCRIPTION
1	C267,050,072.33	Access Door - Indicate Model # & S/N
2	A275,050,100.03	Hinge W/A - Indicate Model # & S/N
3	A267,050,170.13	Latch
4	B267,050,430.13	Changer Guard
5	B267,050,570.03	Back Coin Chute
6	B267,050,560.03	Coin Chute
7	801,804,300.01	Change Hopper
8	804,200,190.01	Vend Sequencer
9	B176,150,290.43	Relay & Changer Socket Bracket
10	804,200,170.01	Relay - Black Plug in
11	904,600,620.01	Socket Relay
12	904,600,600.01	Socket Coin Changer
13	801,804,220.01	Delivery Chute
14	B169,050,371.13	Reinforcement Strip
15	A176,150,330.13	Port Retainer
16	900,301,500.01	Screw #8-1/2"
17	B172,050,031.33	Closure Strip
18	900,300,230.01	Screw #8 x 1 S/M
19	A900,500,260.01	Shoulder Screw

WHEN ORDERING PARTS, INDICATE MODEL # AND SERIAL # OF VENDER.  
 ALL PRICES ARE SUBJECT TO CHANGE WITHOUT NOTICE.

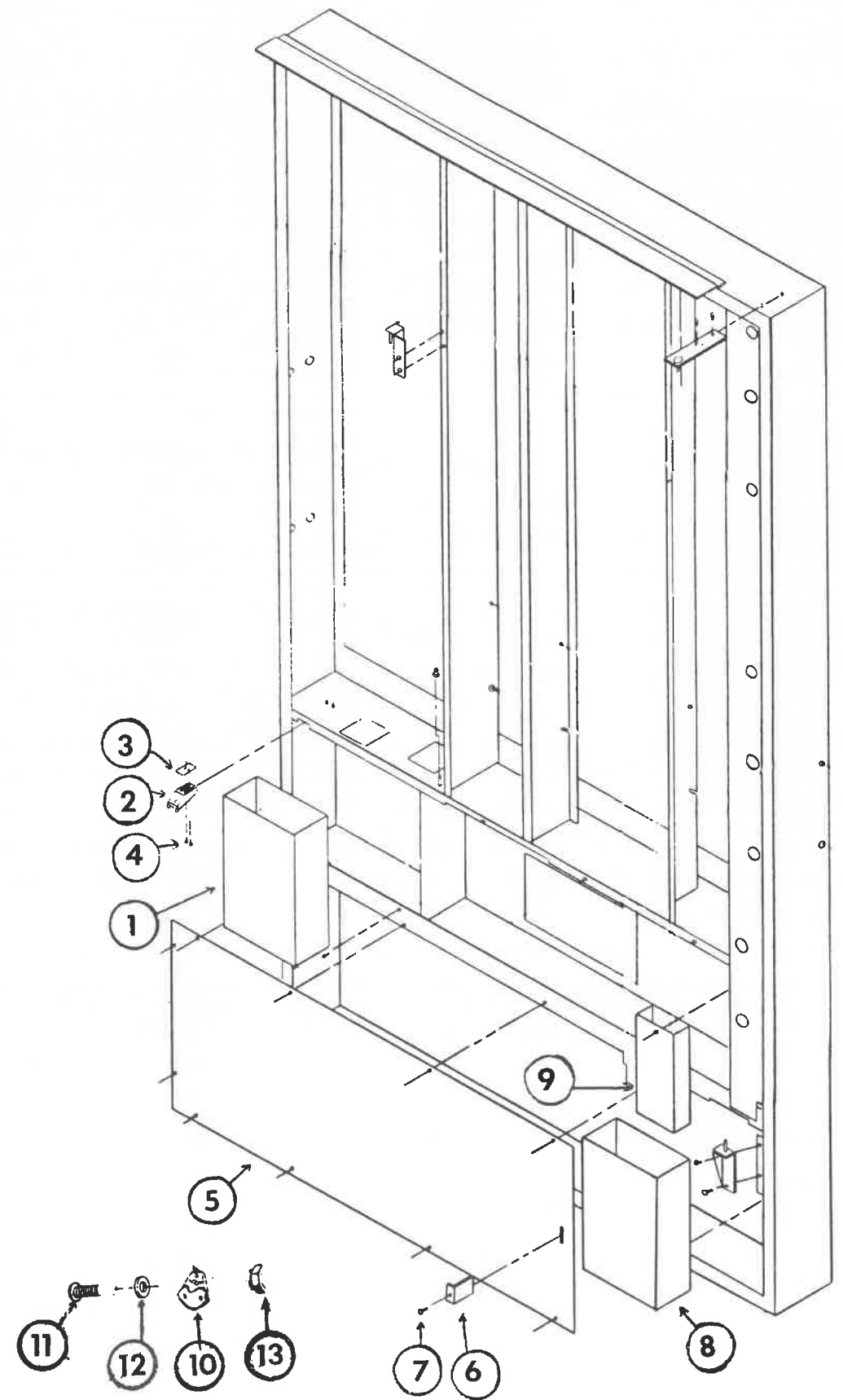

**MAIN DOOR ASSEMBLY**  
 (All 1¼" Deeper DNCB Models)

Item No.	PART NUMBER	PART NAME AND DESCRIPTION
1	B267,052,600.03	Cash Box - S/N
2	801,501,620.01	Strike, Latch
3	801,501,630 01	Strike, Plate Latch
4	900,301,650.01	Screws, Plate Latch
5	B164,050,051.03	Door Stiffener 36¾" Cab.
5-A	B275,050,090.33	Door Stiffener 28" Cab.
6	A267,050,720.03	Bracket
7	900,301,500.01	Screw
8	B275,050,200.03	Crown Catcher
9	B267,050,520.13	Crown Chute
10	901,000,190.02	Crown Puller
11	900,300,350.01	Screw, 10-32
12	903,000,170.02	Washer, #10
13	900,900,960.02	Nut, 10-32

WHEN ORDERING PARTS INDICATE MODEL # AND SERIAL # OF VENDER.  
 ALL PRICES ARE SUBJECT TO CHANGE WITHOUT NOTICE.

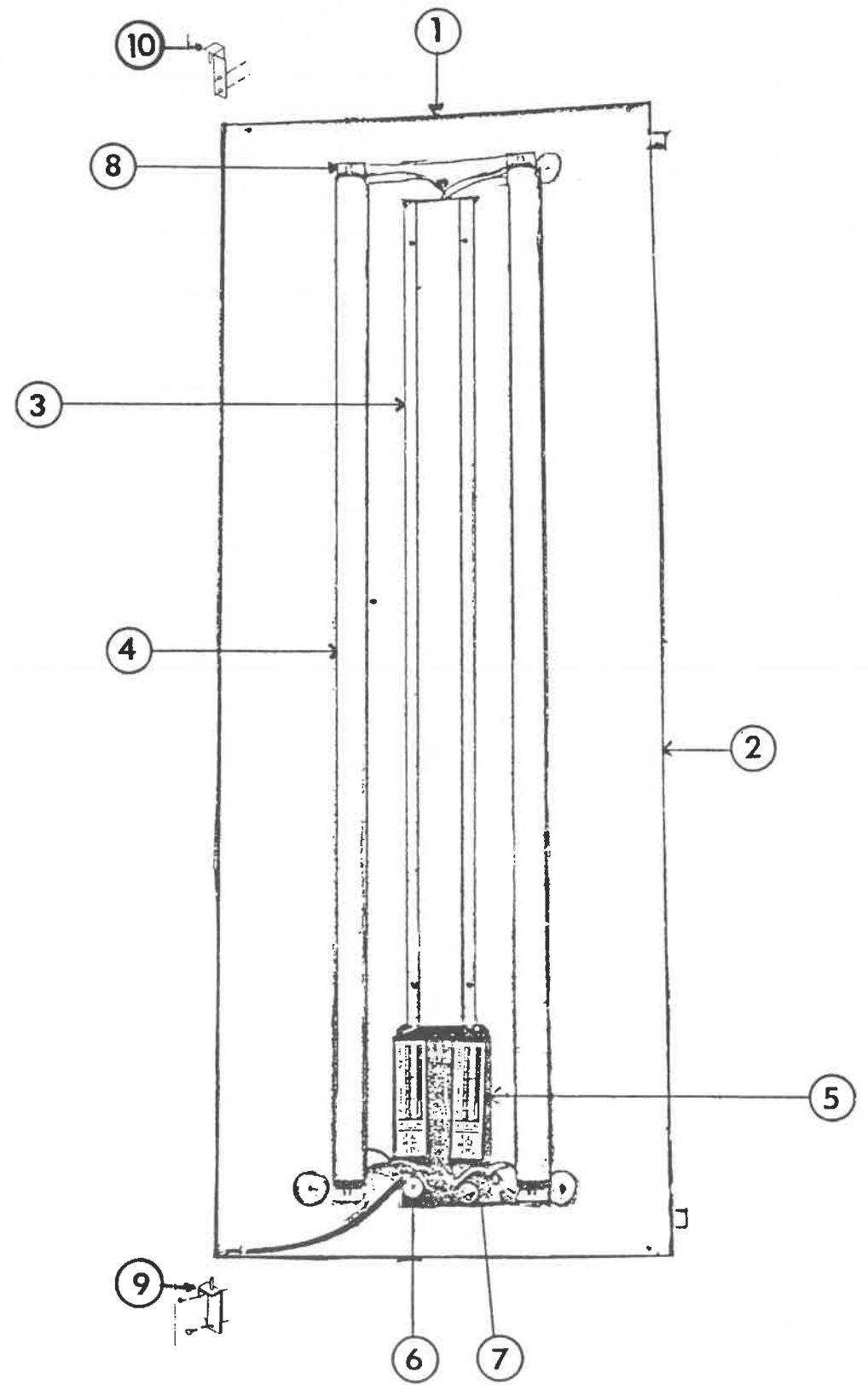



LAMP PANEL DOOR ASSEMBLY  
DNCB 276 / 162

Item No.	PART NUMBER	PART NAME AND DESCRIPTION
1	D278,050,100.03	Lamp Panel Door Ass'y.
2	D278,050,030.03	Lamp Panel Door Only
3	B270,050,070.03	Wire Cover
4	804,700,260.01	Lamp Bulb (30W) (36" Long)
5	804,400,140.01	Ballast - S40BP
6	904,800,540.01	Starter FS-4
7	904,900,710.01	Starter Socket
8	904,901,230.01	Lamp Holder
9	A267,051,500.03	Bottom Hinge - Lamp Panel Door
10	A275,050,100.03	Top Hinge - Lamp Panel Door
<b>DNCB 240 / 138</b>		
1	D276,050,100.03	Lamp Panel Door Ass'y.
2	D276,050,040.03	Lamp Panel Door Only
3	B270,050,070.03	Wire Cover
4	804,700,150.01	Lamp - Bulb (25W) (33" Long)
5	804,400,160.01	Ballast - SP 25 B
6	904,800,410.01	Starter FS 25
7	904,900,710.01	Starter Socket
8	904,901,230.01	Lamp Holder
9	A267,051,500.03	Bottom Hinge - Lamp Panel Door
10	A275,050,100.03	Top Hinge - Lamp Panel Door
<b>DNCB 168 / 99</b>		
1	D275,050,500.03	Lamp Panel Door Ass'y.
2	D275,050,220.13	Lamp Panel Door Only
3	B275,050,210.03	Wire Cover
4	804,700,050.01	Lamp Bulb (20W) (24" Long)
5	804,400,160.01	Ballast - SP25B
6	904,800,410.01	Starter FS-25
7	904,900,710.01	Starter Socket
8	904,901,230.01	Lamp Holder
9	A267,051,500.03	Bottom Hinge - Lamp Panel Door
10	A275,050,100.03	Top Hinge - Lamp Panel Door

WHEN ORDERING PARTS INDICATE MODEL # AND SERIAL # OF VENDER  
ALL PRICES ARE SUBJECT TO CHANGE WITHOUT NOTICE.

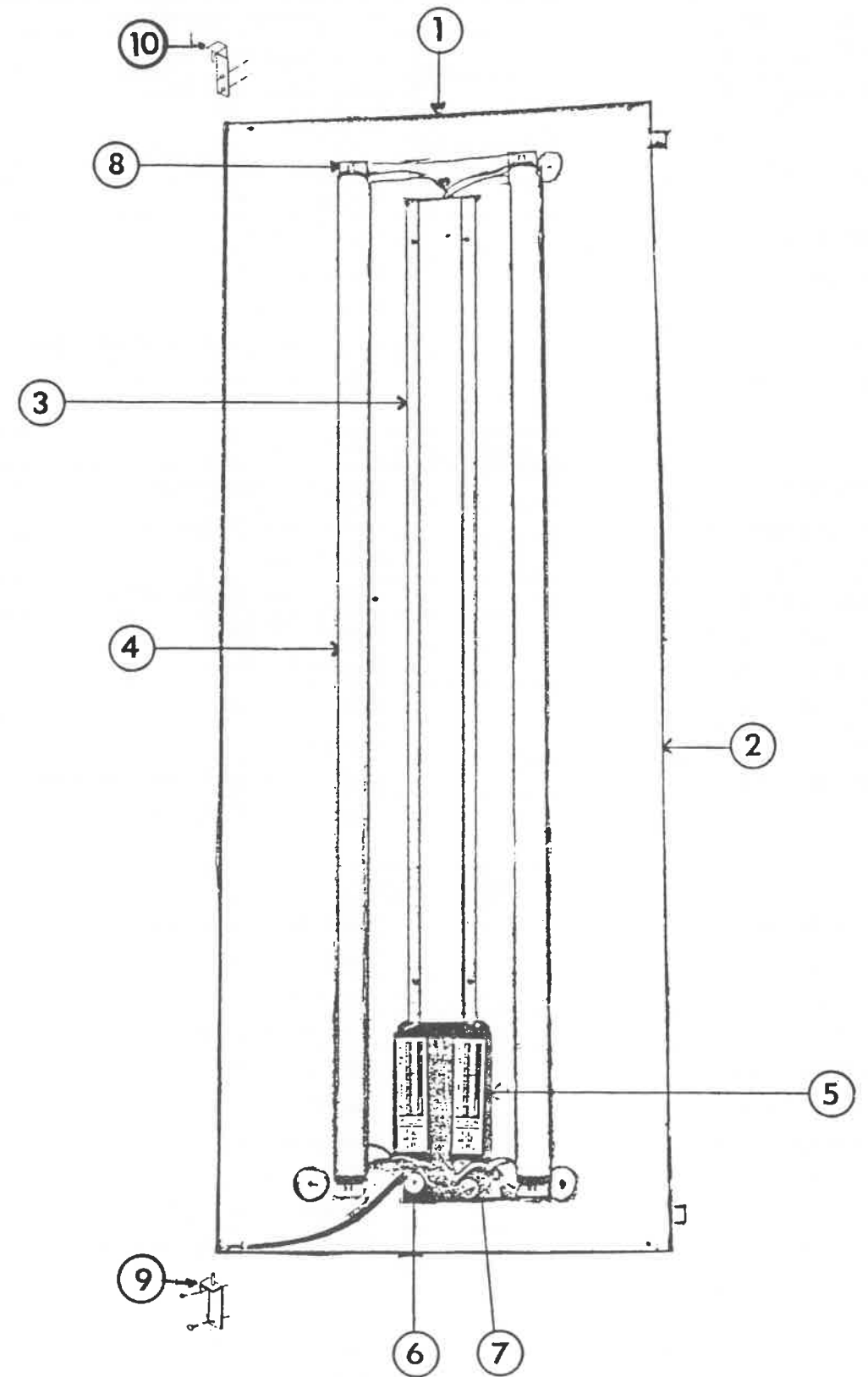

**LAMP PANEL DOOR ASSEMBLY**  
**DNCB 440/252 – 432/246 – 414/239**

Item No.	PART NUMBER	PART NAME AND DESCRIPTION
1	C267,052,100.03	Lamp Panel Door Ass'y.
2	D267,050,660.03	Lamp Panel Door Only
3	B267,050,630.03	Wire Cover
4	804,700,250.01	Lamp Bulb (40W) (48" Long)
5	804,400,140.01	Ballast - S40BP
6	904,800,540.01	Starter FS-4
7	904,900,710.01	Starter Socket
8	904,901,230.01	Lamp Holder
9	A267,051,500.03	Bottom Hinge - Lamp Panel Door
10	A275,050,100.03	Top Hinge - Lamp Panel Door
<b>DNCB 368/216 – 360/210 – 348/206</b>		
1	C270,050,300.03	Lamp Panel Door Ass'y.
2	D270,050,090.03	Lamp Panel Door Only
3	B270,050,070.03	Wire Cover
4	804,700,260.01	Lamp - Bulb (30W) (36" Long)
5	804,400,140.01	Ballast - S40BP
6	904,800,540.01	Starter FS-4
7	904,900,710.01	Starter Socket
8	904,901,230.01	Lamp Holder
9	A267,051,500.03	Bottom Hinge - Lamp Panel Door
10	A275,050,100.03	Top Hinge - Lamp Panel Door
<b>DNCB 320/184 – 304/174</b>		
1	C272,050,200.03	Lamp Panel Door Ass'y.
2	D272,050,090.03	Lamp Panel Door Only
3	B270,050,070.03	Wire Cover
4	804,700,150.01	Lamp Bulb (25W) (33" Long)
5	804,400,160.01	Ballast - SP25B
6	904,800,410.01	Starter FS-25
7	904,900,710.01	Starter Socket
8	904,901,230.01	Lamp Holder
9	A267,051,500.03	Bottom Hinge - Lamp Panel Door
10	A275,050,100.03	Top Hinge - Lamp Panel Door

WHEN ORDERING PARTS, INDICATE MODEL # AND SERIAL # OF VENDER.  
 ALL PRICES ARE SUBJECT TO CHANGE WITHOUT NOTICE.

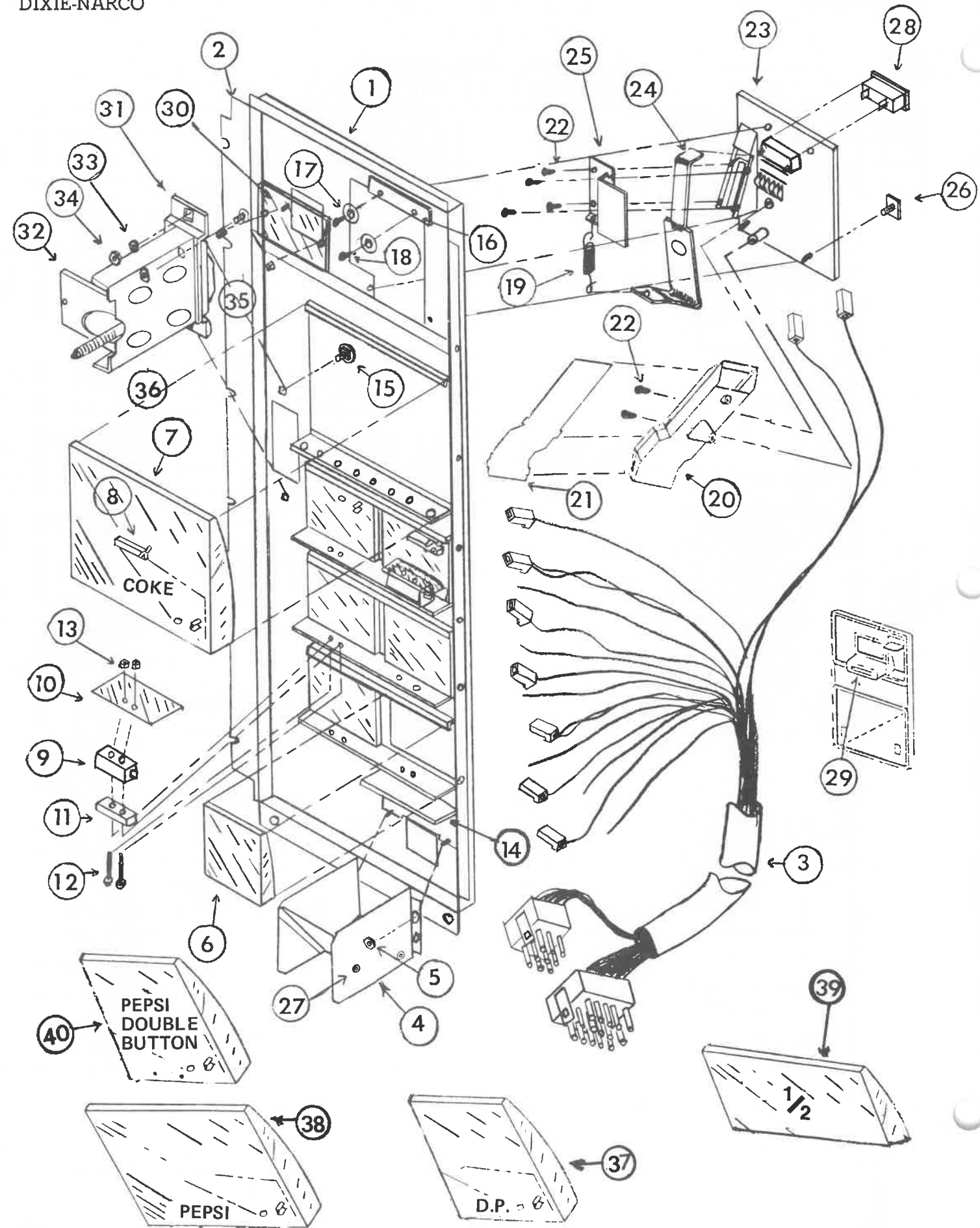

Parts List

**CONTROL PANEL ASSEMBLY**  
(All 1 1/4" Deeper DNCB Models)

Item No.	PART NUMBER	PART NAME AND DESCRIPTION
1	Indicate Model #, Serial # & Trademark	Control Panel Ass'y. - Includes Items 1-36
2	Indicate Model #, Serial # & Trademark	Control Panel W/A
3	Indicate Model #, Serial # & Trademark	Wiring Harness Assembly
4	360,051,500.03	Coin Return Cup Assembly
5	900,800,500.01	Keps Nut 8-32
6	801,804,510.01	Select Button (Little Square) 3"x 2 1/4"
7	801,804,580.01	Coke Select Button (Large Rectangular) 5 1/2" x 6 3/4"
8	804,700,210.01	Lamp, Sold Out
9	804,100,510.01	Switch, Select
10	801,804,620.01	Switch Shield & Spring
11	A901,804,540.01	Button Stop
12	900,201,310.01	Machine Screw
13	900,800,490.01	Keps Nut #6-32
14	A267,050,610.13	Cover Change Cup
15	900,201,200.01	Carriage Bolt & Nut
16	A143,051,220.73	Retainer, Coin Insert
17	900,700,020.01	Washer Flat
18	900,300,160.01	Screw #6 S/M
19	901,700,630.11	Spring Coin Return
20	801,805,380.01	Coin Chute,
21	801,805,370.11	Cover Coin Chute,
21A	A356,050,100.03	W/A Back Coin Chute Cover Coin Chute Gray 10 Column Coke only
22	900,300,110.01	Screw S/M
23	D801,200,920.21	Coin Insert Only
24	B801,303,610.01	Plunger Coin Return
24A	B356,050,200.03	W/A Plunger Coin Return Plunger Coin Return 10 Column Coke only
25	A208,050,120.53	Plunger, Retainer
26	902,700,160.02	Tee Bolts - 8-32 x 1/2"
27	901,100,390.01	Pop Rivets
28	904,700,180.31	Lamp, Correct Change
29	B/M213,010,600.04 (Items 16-28)	Coin Insert Assembly - Complete
29A	356,050,300.03	Coin Insert Ass'y. Complete 10 Col. Coke only
30	C801,804,550.01	Price Window
31	B267,050,480.13	Handle Mount
32	B267,050,191.33	Brace Tee Handle
33	900,700,390.01	Lock Washer
34	900,900,480.01	Nut, Hex
35	900,901,510.02	Machine Screw
36	900,900,960.01	Hex Nut
37	801,804,430.01	Select Button (Large Square) D.P. 5 1/2" x 5 1/2"
38	801,804,830.01	Select Button (Pepsi) 6 1/2" x 5"
39	801,804,820.01	Select Button (1/2) 2 3/4" x 7"
40	801,805,010.01	Select Button Double Button - 5 1/2" x 5 1/2"

WHEN ORDERING PARTS, INDICATE MODEL # AND SERIAL # OF VENDER.  
ALL PRICES ARE SUBJECT TO CHANGE WITHOUT NOTICE.

3027

3X24  
801804510A1

INNER DOOR

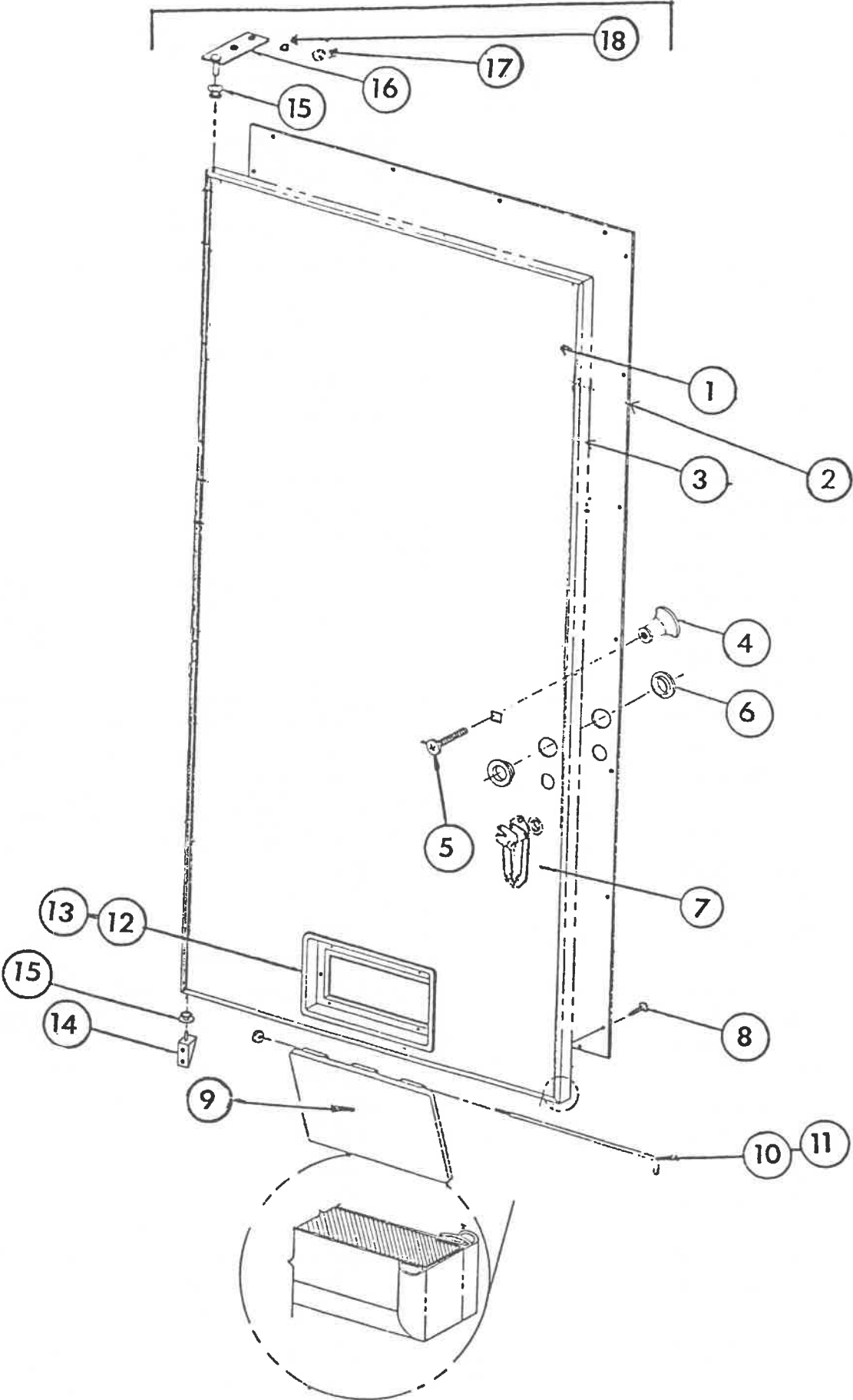

INNER DOOR ASSEMBLY  
(All DNCR Venders)

Item No.	PART NUMBER	PART NAME AND DESCRIPTION
1	Indicate Model #, Serial #, & Trademark	Inner Door Assembly
2	Indicate Model #, Serial #, & Trademark	Rear Panel, Replacement
3	Indicate Model #, Serial #, & Trademark	Gasket Inner Door
4	901,501,700.01	Knob
5	900,201,230.01	Carriage Bolt 1/4-20
6	901,901,360.01	Snap Bushing
7	A169,053,100.53	Burst Open Latch W/A
8	900,301,500.01	Screw, Self Drilling #8 x 1/2"
9	801,804,200.01	Delivery Door
10	A169,050,530.01	Hinge Pin
11	900,800,580.01	Lock Nut, Elastic
12	801,804,210.01	Frame Inner Door
13	901,100,460.01	Pop Rivet
14	A169,051,101.33	Inner Door Hinge, Bottom
15	901,803,710.01	Nyliner, Door Hinge
16	A169,053,001.03	Inner Door Hinge, Top
17	900,900,960.03	Nut 10-32, Top Hinge
18	903,000,170.01	Washer, Lock

WHEN ORDERING PARTS, INDICATE MODEL # AND SERIAL # OF VENDER.  
ALL PRICES ARE SUBJECT TO CHANGE WITHOUT NOTICE.

DIXIE-NARCO

3 way pig tail  
275 050 300.03

4 way pig tail  
w/ long harness  
267 051 800.03

4 way pig tail  
w/ short harness  
267, 050, 800.03

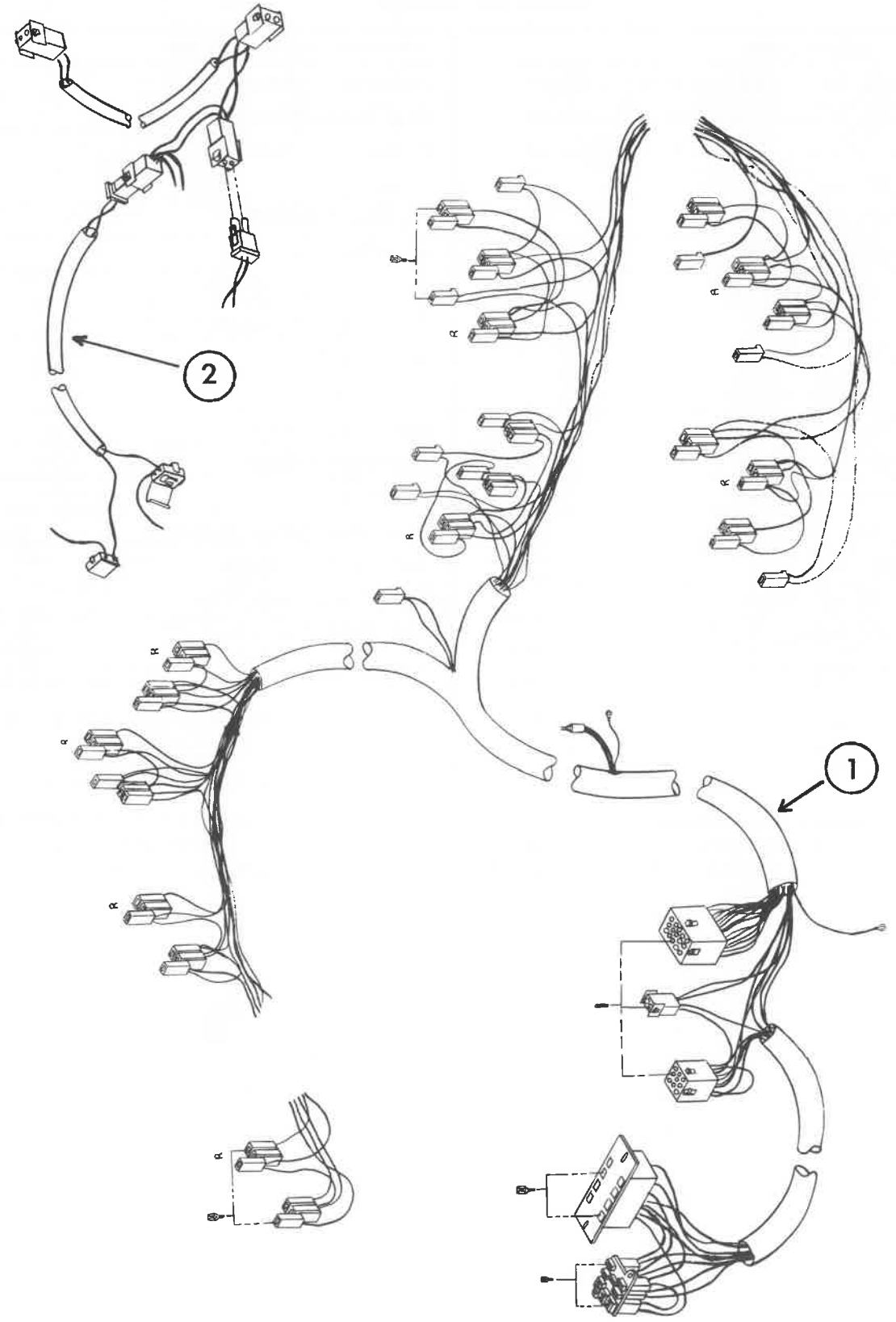



**WIRING HARNESS  
(All DNCB Venders)**

Item No.	PART NUMBER	PART NAME AND DESCRIPTION
1	Indicate Model #, Serial #, & Trademark	Wiring Harness Cabinet-Door
2	B267,051,800.03	Jump Lamp Panel

WHEN ORDERING PARTS, INDICATE MODEL # AND SERIAL # OF VENDER.  
ALL PRICES ARE SUBJECT TO CHANGE WITHOUT NOTICE.

DNCB HINGES ASSY. LIFTER, ROLLER,  
PULL OUT HANDLE - LOCK & KEYS

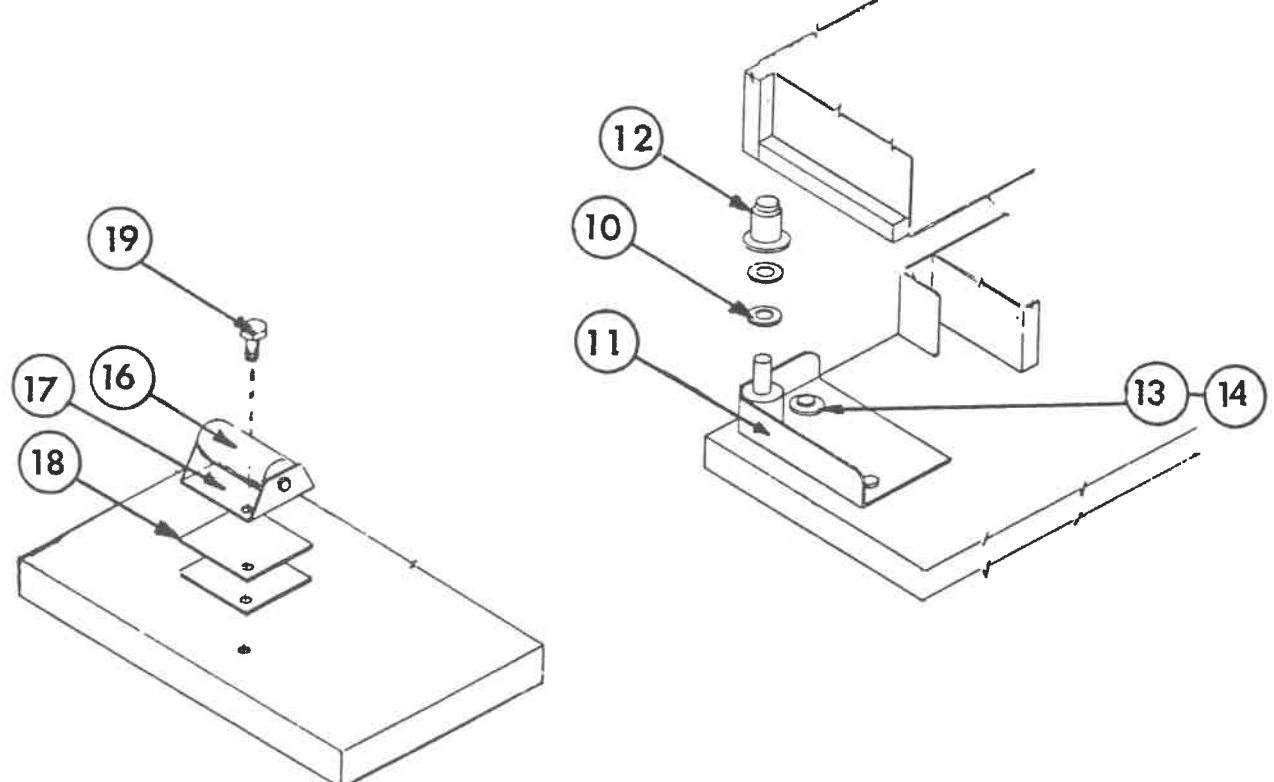
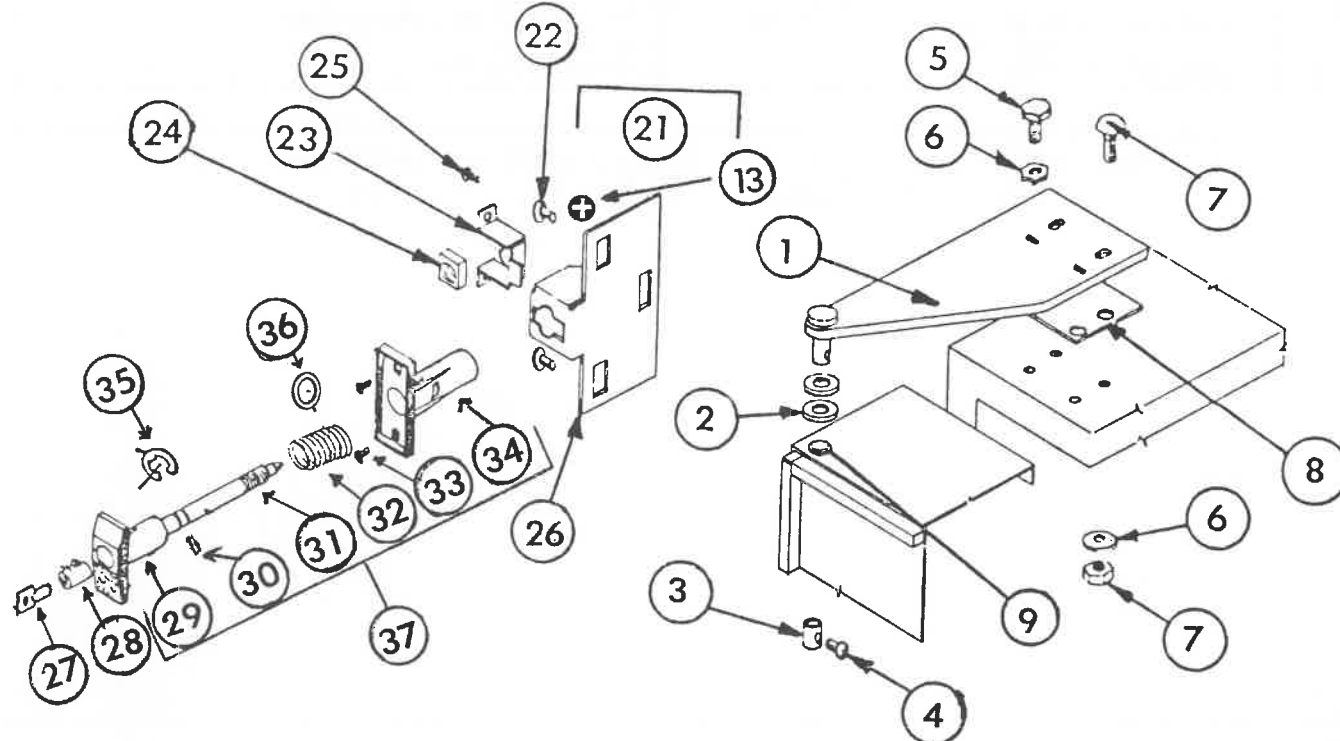

**HINGES AND HANDLE**  
 (All DNCB Venders)

Item No.	PART NUMBER	PART NAME AND DESCRIPTION
1	B801,501,710.31	Top Hinge
2	900,700,600.01	Flat Washer
3	A800,502,030.01	Collar, Hinge Pin
4	A900,201,260.01	Lock Screw
5	900,301,710.01	Screw 1/4 - 20 Self Tapping
6	903,000,070.02	Lockwasher, 1/4-20
7	900,201,170.01	Carriage Bolt and Nut
8	A169,000,150.13	Hinge Spacer
9	801,803,170.01	Bearing Nyliner
10	900,700,530.01	Washer
11	B169,000,100.93	Bottom Hinge, W/A
12	A901,800,330.51	Flanged Bushing
13	900,700,710.01	Lockwasher-Pyramidal Type
14	900,301,710.01	Screw 1/4 x 20 Self Tapping
16	A801,801,330.51	Roller
17	A142,161,700.63	Assembly Lifter & Roller
18	A142,160,580.43	Spacer, Roller Bracket
19	900,901,510.02	Screw, machine 10-32 x 5/8
21	B169,000,080.93	Latch Strike Assembly
22	900,301,710.01	Screw, machine 1/4 x 20 Self Tapping
23	B801,303,320.61	Nut, Housing
24	A900,800,570.11	Nut
25	900,301,560.01	Screw
26	B176,150,160.33	Nut Retainer Housing
27	Specify Key Number	Keys Only - Specify Trademark
28	Specify Key Number	Lock w/2 Keys - Specify Trademark
29		Handle
30	20-31	Pin
31	Indicate Model #, Serial #, & Trademark	Stud
32	901,700,640.01	Spring
33	900,901,510.02	Screws, 10-32 x 5/8"
34		Body
35	31-5	C-Clip
36	900,700,760.01	Washer
37	801,502,100.01	Handle Ass'y. (Items 29-36)

WHEN ORDERING PARTS, INDICATE MODEL # AND SERIAL # OF VENDER.  
 ALL PRICES ARE SUBJECT TO CHANGE WITHOUT NOTICE.

DIXIE-NARCO

CABINET AND VEND MECHANISM

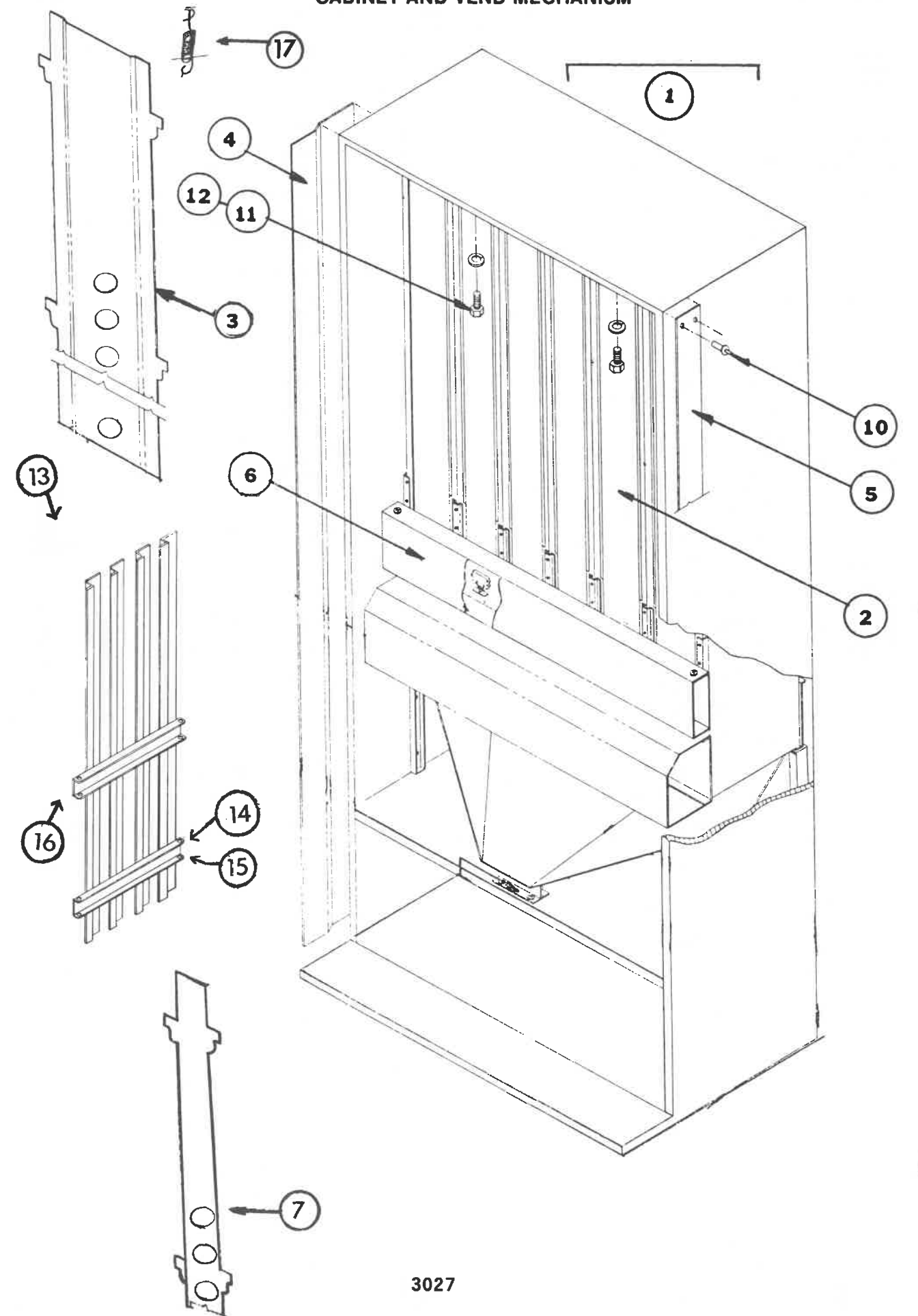

Parts List

CABINET AND VEND MECHANISM

DIXIE-NARCO

Item No.	PART NUMBER	PART NAME AND DESCRIPTION
DNCB 168/99-5 & -6		
1	D154,060,001.73	Cabinet Ass'y. Less Stack
2	F275,070,000.03	Vend Mechanism Complete -5
2b	F291,070,000.03	Vend Mechanism Complete - 6
3	C275,070,200.03	Bottle Guide Standard Column
4	C168,000,030.83	Protective Plate L.S. Cabinet
5	C168,000,040.83	Protective Plate R.S. Cabinet
6	F275,071,000.03	Stack w/Ass'y. w/Gate Installed
7	C275,070,300.03	Bottle Guide Narrow Column
10	901,100,440.01	Drive Rivet 1/4
11	900,301,710.01	Screw 1/4 - 20 Self Tapping
12	903,000,070.01	Washer
13	B275,070,100.13	W/A Gate
14	A231,070,300.03	W/A Gate Hinge
15	901,100,390.01	Pop Rivet
16	A231,070,260.03	Gate Latch
17	901,700,690.51	Spring, Rear Guide
DNCB 240/138-5 & -6		
1	D155,060,001.73	Cabinet Ass'y. Less Stack
2	F276,070,000.03	Vend Mechanism Complete -5
2b	F289,070,000.03	Vend Mechanism Complete - 6
3	C272,070,200.03	Bottle Guide Standard Column
4	C166,000,030.93	Protective Plate L.S. Cabinet
5	B166,000,040.83	Protective Plate R.S. Cabinet
6	F276,071,000.03	Stack w/Ass'y. w/Gate Installed
7	C272,070,300.03	Bottle Guide Narrow Column
10	901,100,440.01	Drive Rivet 1/4
11	900,301,710.01	Screw 1/4-20 Self Tapping
12	903,000,070.01	Washer
13	C276,070,100.03	W/A Gate
14	A231,070,300.03	W/A Gate Hinge
15	901,100,390.01	Pop Rivet
16	A231,070,260.03	Gate Latch
17	901,700,690.51	Spring, Rear Guide
DNCB 276/162-5 & -6		
1	D215,060,000.23	Cabinet Ass'y. Less Stack
2	F278,070,000.03	Vend Mechanism Complete -5
2b	F292,070,000.03	Vend Mechanism Complete - 6
3	C270,070,200.03	Bottle Guide Standard Column
4	C165,000,030.73	Protective Plate L.S. Cabinet
5	B165,000,040.73	Protective Plate R.S. Cabinet
6	F278,071,000.03	Stack w/Ass'y. w/Gate Installed
7	C270,070,300.03	Bottle Guide Narrow Column
10	901,100,440.01	Drive Rivet 1/4
11	900,301,710.01	Screw 1/4-20 Self Tapping
12	903,000,070.02	Washer
13	C278,070,100.03	W/A Gate
14	A231,070,300.03	W/A Gate Hinge
15	901,100,390.01	Pop Rivet
16	A231,070,260.03	Gate Latch
17	901,700,690.51	Spring, Rear Guide

WHEN ORDERING PARTS, INDICATE MODEL # AND SERIAL # OF VENDER.  
ALL PRICES ARE SUBJECT TO CHANGE WITHOUT NOTICE.

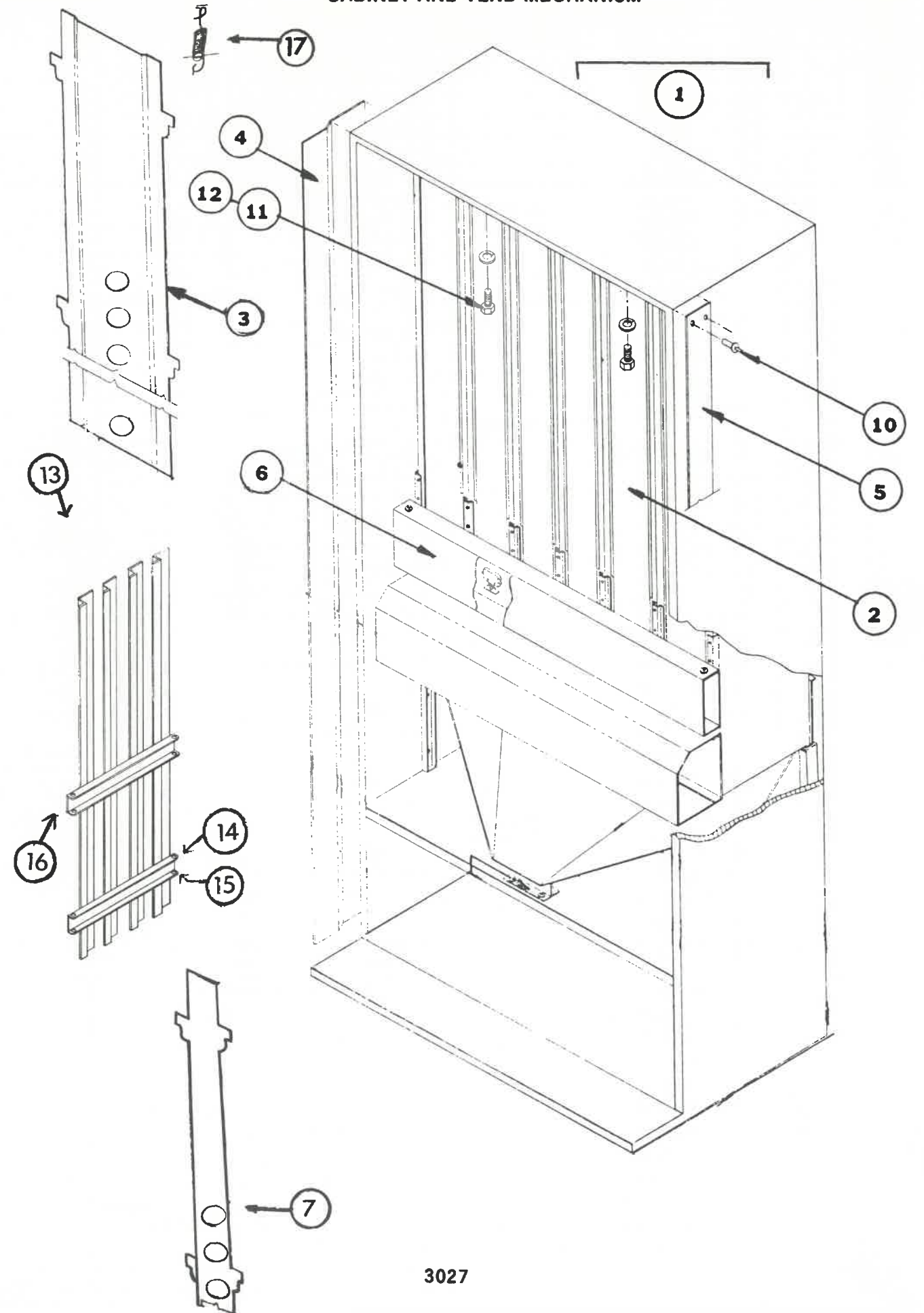

Parts List

CABINET AND VEND MECHANISM

DIXIE-NARCO

Item No.	PART NUMBER	PART NAME AND DESCRIPTION
DNCB 330/189-5 & -6		
1	D156,060,001.53	Cabinet Ass'y. Less Stack
2	F279,070,000.03	Vend Mechanism Complete -5
2b	F293,070,000.03	Vend Mechanism Complete -6
3	C267,070,200.03	Bottle Guide Standard Column
4	C164,000,030.93	Protective Plate L.S. Cabinet
5	B164,000,040.93	Protective Plate R.S. Cabinet
6	F279,071,000.03	Stack w/Ass'y. w/Gate Installed
7	C267,070,300.03	Bottle Guide Narrow Column
10	901,100,440.01	Drive Rivet 1/4
11	900,301,710.01	Screw 1/4 - 20 Self Tapping
12	903,000,070.02	Washer
13	C237,070,500.03 A	W/A Gate
14	A231,070,300.03	W/A Gate Hinge
15	901,100,390.01	Pop Rivet
16	A231,070,260.03	Gate Latch
17	901,700,690.51	Spring, Rear Guide
DNCB 320/184-7 & -8		
1	D166,060,001.13	Cabinet Ass'y. Less Stack
2	F272,070,000.03	Vend Mechanism Complete -7
2b	F277,070,000.03	Vend Mechanism Complete -8
3	C272,070,200.03	Bottle Guide Standard Column
4	C166,000,030.93	Protective Plate L.S. Cabinet
5	B166,000,040.83	Protective Plate R.S. Cabinet
6	F272,071,000.03	Stack w/Ass'y. w/Gate Installed
7	C272,070,300.03	Bottle Guide Narrow Column
10	901,100,440.01	Drive Rivet 1/4
11	900,301,710.01	Screw 1/4-20 Self Tapping
12	903,000,070.01	Washer
13	C272,070,100.03	W/A Gate
14	A231,070,300.03	W/A Gate Hinge
15	901,100,390.01	Pop Rivet
16	A231,070,260.03	Gate Latch
17	901,700,690.51	Spring, Rear Guide
DNCB 368/216-7 & -8		
1	D165,060,001.23	Cabinet Ass'y. Less Stack
2	F270,070,000.03	Vend Mechanism Complete -7
2b	F274,070,000.03	Vend Mechanism Complete -8
3	C270,070,200.03	Bottle Guide Standard Column
4	C165,000,030.73	Protective Plate L.S. Cabinet
5	B165,000,040.73	Protective Plate R.S. Cabinet
6	F270,071,000.03	Stack w/Ass'y. w/Gate Installed
7	C270,070,300.03	Bottle Guide Narrow Column
10	901,100,440.01	Drive Rivet 1/4
11	900,301,710.01	Screw 1/4-20 Self Tapping
12	903,000,070.02	Washer
13	C270,070,100.03	W/A Gate
14	A231,070,300.03	W/A Gate Hinge
15	901,100,390.01	Pop Rivet
16	A231,070,260.03	Gate Latch
17	901,700,690.51	Spring, Rear Guide

WHEN ORDERING PARTS, INDICATE MODEL # AND SERIAL # OF VENDER.  
ALL PRICES ARE SUBJECT TO CHANGE WITHOUT NOTICE.

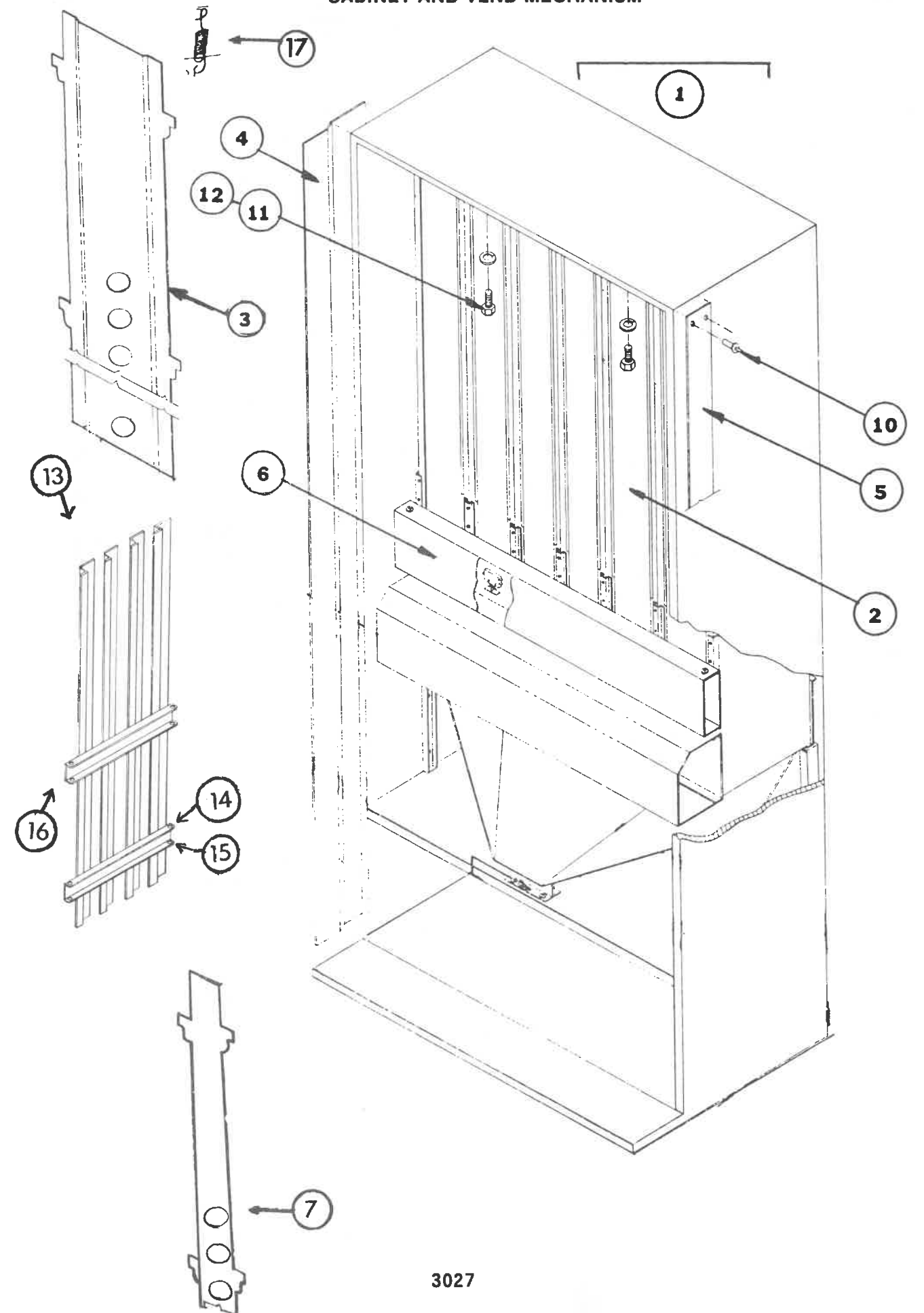



## CABINET AND VEND MECHANISM

Item No.	PART NUMBER	PART NAME AND DESCRIPTION
		DNCB 440/252-7 & -8
1	D164,060,001.23	Cabinet Ass'y. Less Stack
2	F267,070,000.03	Vend Mechanism Complete -7
2b	F269,070,000.03	Vend Mechanism Complete -8
3	C267,070,200.03	Bottle Guide Standard Column
4	C164,000,030.93	Protective Plate L.S. Cabinet
5	B164,000,040.93	Protective Plate R.S. Cabinet
6	F267,071,000.03	Stack w/Ass'y. w/Gate Installed
7	C267,070,300.03	Bottle Guide Narrow Column
10	901,100,440.01	Drive Rivet 1/4
11	900,301,710.01	Screw 1/4-20 Self Tapping
12	903,000,070.02	Washer
13	C267,070,100.03	W/A Gate
14	A231,070,300.03	W/A Gate Hinge
15	901,100,390.01	Pop Rivet
16	A231,070,260.03	Gate Latch
17	901,700,690.51	Spring, Rear Guide

WHEN ORDERING PARTS, INDICATE MODEL # AND SERIAL # OF VENDER.  
ALL PRICES ARE SUBJECT TO CHANGE WITHOUT NOTICE.

DIXIE-NARCO

CABINET AND VEND MECHANISM

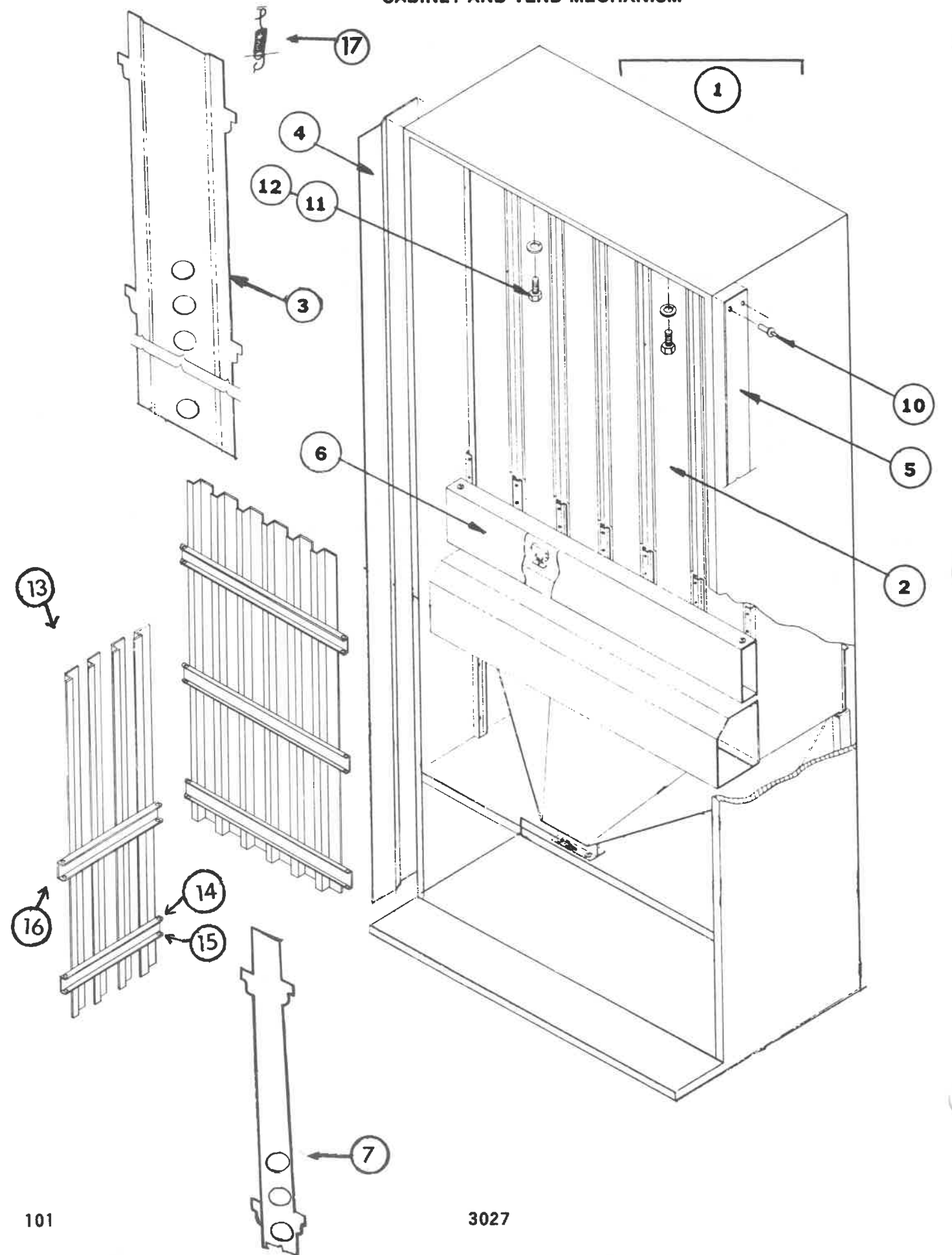

Item No.	PART NUMBER	PART NAME AND DESCRIPTION
<b>DNCB 414/239-9 &amp; 10</b>		
1	D164,060,001.63	Cabinet Ass'y. less Stack
2	F356,070,000.03	Vend Mechanism Complete 9
3	F350,070,000.03	Vend Mechanism Complete 10
3	C267,070,200.03	Bottle Guide Standard Column
4	C164,000,031.13	Protective Plate L.S. Cabinet
5	B164,000,041.13	Protective Plate R.S. Cabinet
6	F350,071,000.03	Stack Ass'y. w/Gates Installed
7	C267,070,300.03	Bottle Guide Narrow Column
10	901,100,440.01	Drive Rivet 1/4"
11	900,301,710.01	Screw 1/4-20 Self Tapping
12	903,000,070.02	Washer
13	C350,070,300.03	W/A Gate - Narrow
13	C350,070,400.03	W/A Gate - Wide
14	A231,070,300.03	W/A Gate Hinge
	A350,070,100.03	W/A Hinge Bottom
14A	A350,070,200.03	W/A Hinge Top
15	901,100,390.01	Pop Rivet
16	A350,070,130.03	Gate Latch
17	901,700,690.51	Spring Rear Guide
<b>DNCB 348/206-9 &amp; 10</b>		
1	D165,060,001.63	Cabinet Ass'y. less Stack
2	F358,070,000.03	Vend Mechanism Complete 9
3	F351,070,000.03	Vend Mechanism Complete 10
3	C270,070,200.03	Bottle Guide Standard Column
4	C165,000,030.93	Protective Plate L.S. Cabinet
5	B165,000,040.93	Protective Plate R.S. Cabinet
6	F351,071,000.03	Stack Ass'y. w/Gates Installed
7	C270,070,300.03	Bottle Guide Narrow Column
10	901,100,440.01	Drive Rivet 1/4"
11	900,301,710.01	Screw 1/4-20 Self Tapping
12	903,000,070.02	Washer
13	C351,070,100.03	W/A Gate - Narrow
13	C351,070,200.03	W/A Gate - Wide
14	A231,070,300.03	W/A Gate Hinge
	A350,070,100.03	W/A Hinge Bottom
14A	A350,070,200.03	W/A Hinge Top
15	901,100,390.01	Pop Rivet
16	A350,070,130.03	Gate Latch
	901,700,690.51	Spring Rear Guide

WHEN ORDERING PARTS, INDICATE MODEL # AND SERIAL # OF VENDER.  
ALL PRICES ARE SUBJECT TO CHANGE WITHOUT NOTICE.

CABINET AND VEND MECHANISM

Parts

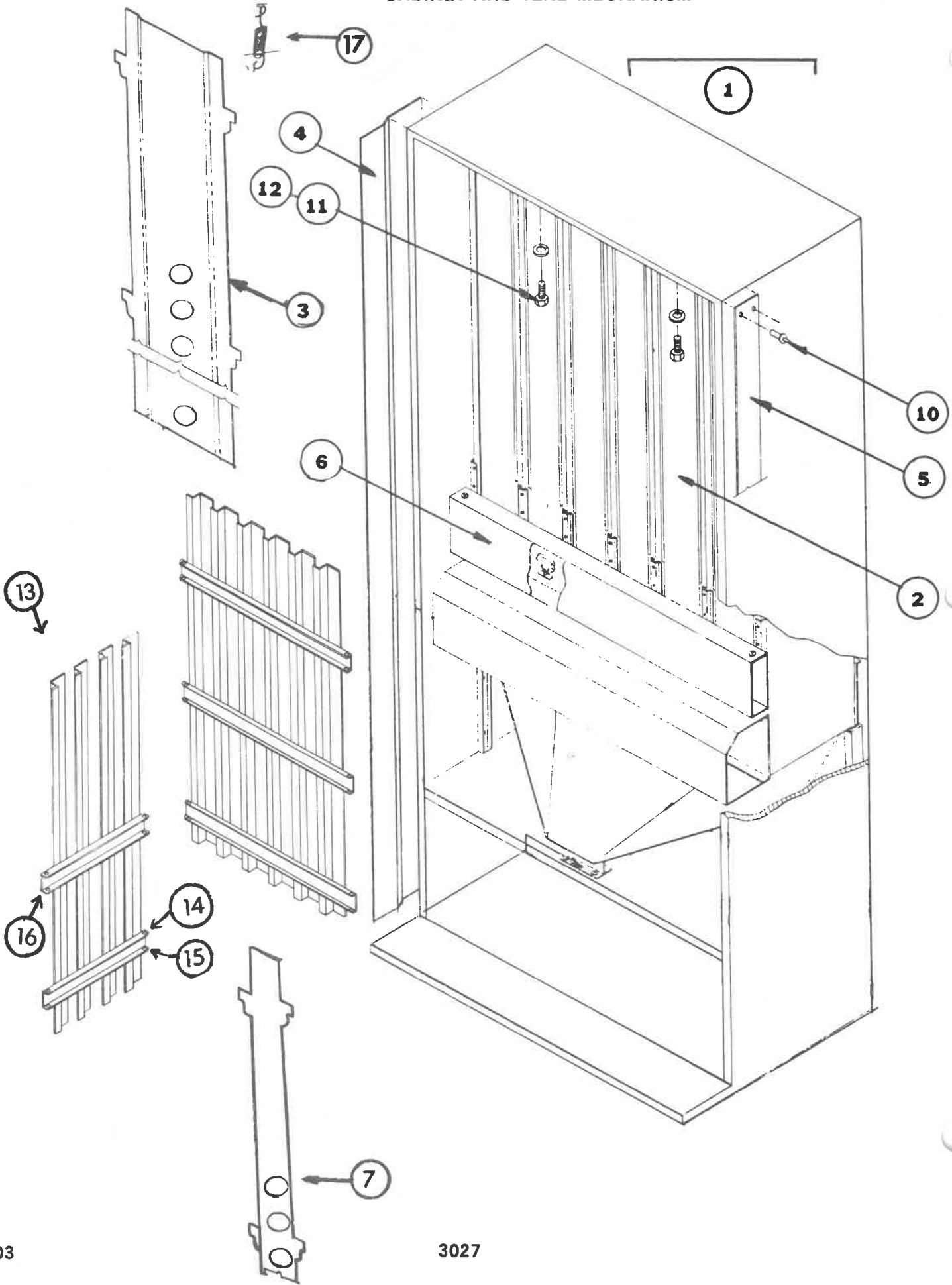



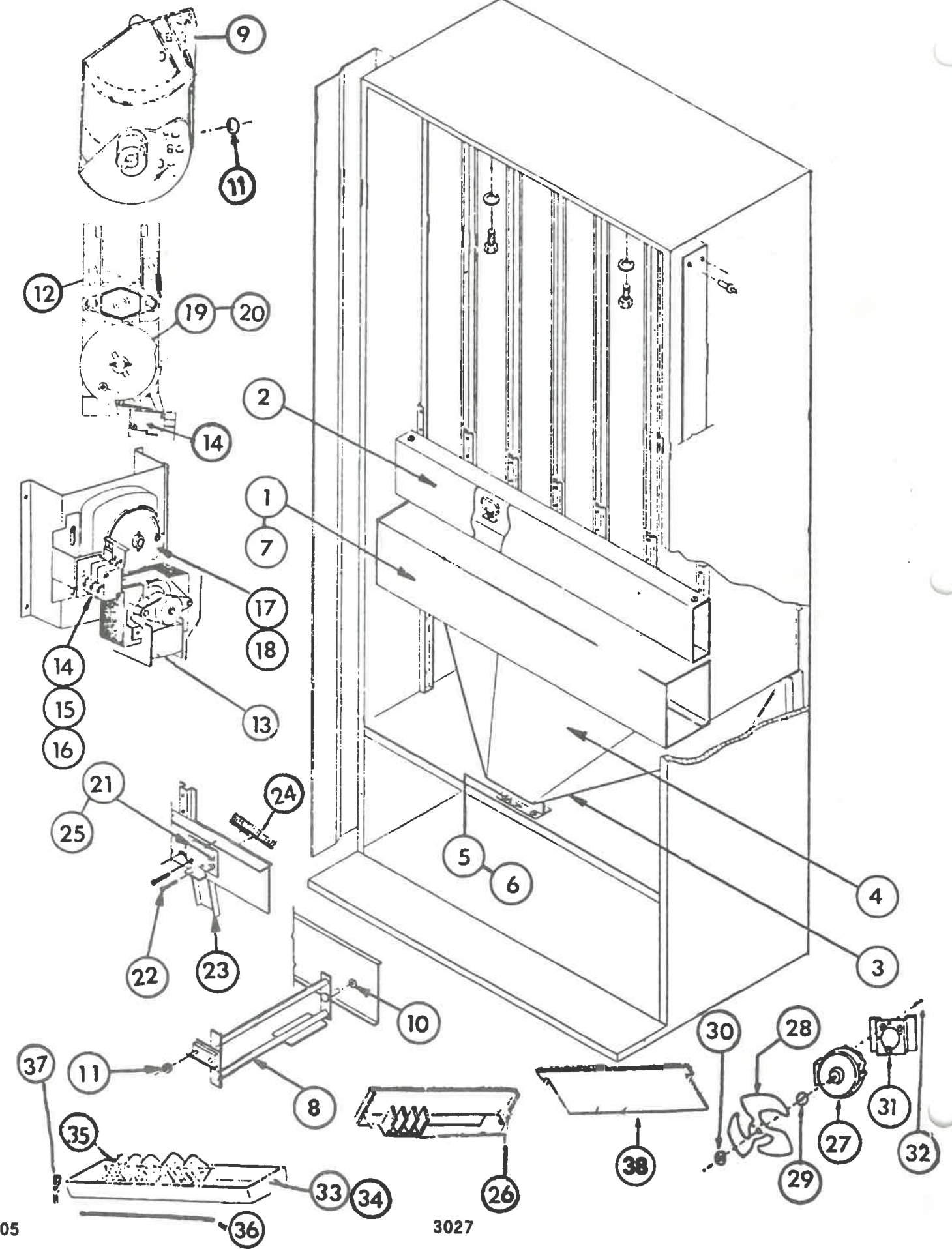

CABINET AND VEND MECHANISM

Item No.	PART NUMBER	PART NAME AND DESCRIPTION
	DNCB 168/99-5 & -6, DNCB 240/138-5 & -6, DNCB 276/162-5 & -6, DNCB 330/189-5 & -6	
1	B237,070,250.03	Cover Vend Motor
2	B237,070,080.03	Cover Sold Out Switch S/A
3	D208,070,010.33	Can & Bottle Chute Ass'y. Complete
4	D208,070,020.53	Liner Only - Chute
	DNCB 440/252-7 & 8 DNCB 368/216-7 & 8 DNCB 320/184-7 & 8 DNCB 304/174-9 & 10 DNCB 348/206-9 & 10 DNCB 414/239-9 & 10	
1	C176,070,250.03	Cover Vend Motor
2	B231,070,220.03	Cover Sold Out Switch S/A
3	D211,070,010.43	Can & Bottle Chute Ass'y. Complete
4	D211,070,020.43	Liner Only - Chute
	DNCB 168/99-5 & 6 DNCB 240/138-5 & 6 DNCB 276/162-5 & 6 DNCB 330/189-5 & 6 DNCB 320/184-7 & 8 DNCB 360/210-5 & 6 DNCB 368/216-7 & 8 DNCB 432/246-5 & 6 DNCB 440/252-7 & 8 DNCB 304/174-9 & 10 DNCB 348/206-9 & 10 DNCB 414/239-9 & 10	
5	B147,074,400.73	Bracket Chute
6	900,900,960.02	Hex Nut - 10-32 (Chute)
7	900,301,560.01	Screw Sems - (Cover, Vend Motor)
8	D801,201,010.01	Oscillator Long 1 1/4
9	D801,201,000.01	Vend Rotor Long 1 1/4
10	801,803,170.01	Nyliner (Rear Stack)
11	801,804,230.01	Nyliner (Oscillator Front & Rotor)
12	C231,070,400.03	Vend Motor (Narrow Column)
13	179,070,600.33	Vend Motor (Red Cam Standard Col.)
14	804,100,500.01	Cluster Switch, Vend Motor
15	900,301,610.01	Screw, Vend Motor Switch
16	905,800,330.01	Insulator, Vend Motor Switch
17	C801,804,090.21	Vend Motor Cam, (RED) Standard
18	C801,804,000.41	Adjustable Cam (WHITE)
19	C801,804,290.01	Adjustable Cam, (RED) Narrow
20	C801,804,090.01	Cam, Vend Motor (Narrow Column)
21	804,100,490.01	Switch, Sold Out Cluster
22	900,301,670.01	Screw, Sold Out Switch #4x1 1/4"
23	C231,070,170.43	Paddle, Sold Out Switch
24	901,700,630.01	Spring, Sold Out Paddle
25	801,804,350.01	Insulator, Switch
26	C801,804,950.01	Shims, 12 oz. Can (Plastic) 1 1/4"
27	B143,000,301.03	Fan Motor S/A - Evap.
28	901,303,270.01	Fan Blade - Evap.
29	900,100,970.02-2	Silencer
30	900,100,970.02-1	Speed Nut
31	B164,040,080.63	Bracket, Fan Motor
32	900,300,320.01	Screw, Self Tapping (10-24)
33	B169,000,200.63	Ass'y. Pan & Soaker
34	C801,804,240.11	Condensate Pan (Only Black)
35	901,900,020.01	Soaker
36	901,400,060.01	Rod, for Soaker 14"
37	900,301,650.01	Screw, Self Drilling
38	801,804,960.01	Flat Shim - Wide Column

10¢  
900 401 090.02  
grommet  
goes on cup Fan  
Bracket + then  
motor mounts on

WHEN ORDERING PARTS, INDICATE MODEL # AND SERIAL # OF VENDER.  
ALL PRICES ARE SUBJECT TO CHANGE WITHOUT NOTICE.

FAN motor 220 volt  
9w 804 500 530.01 only 20 of them  
6w 804 500 520.01 in new kit

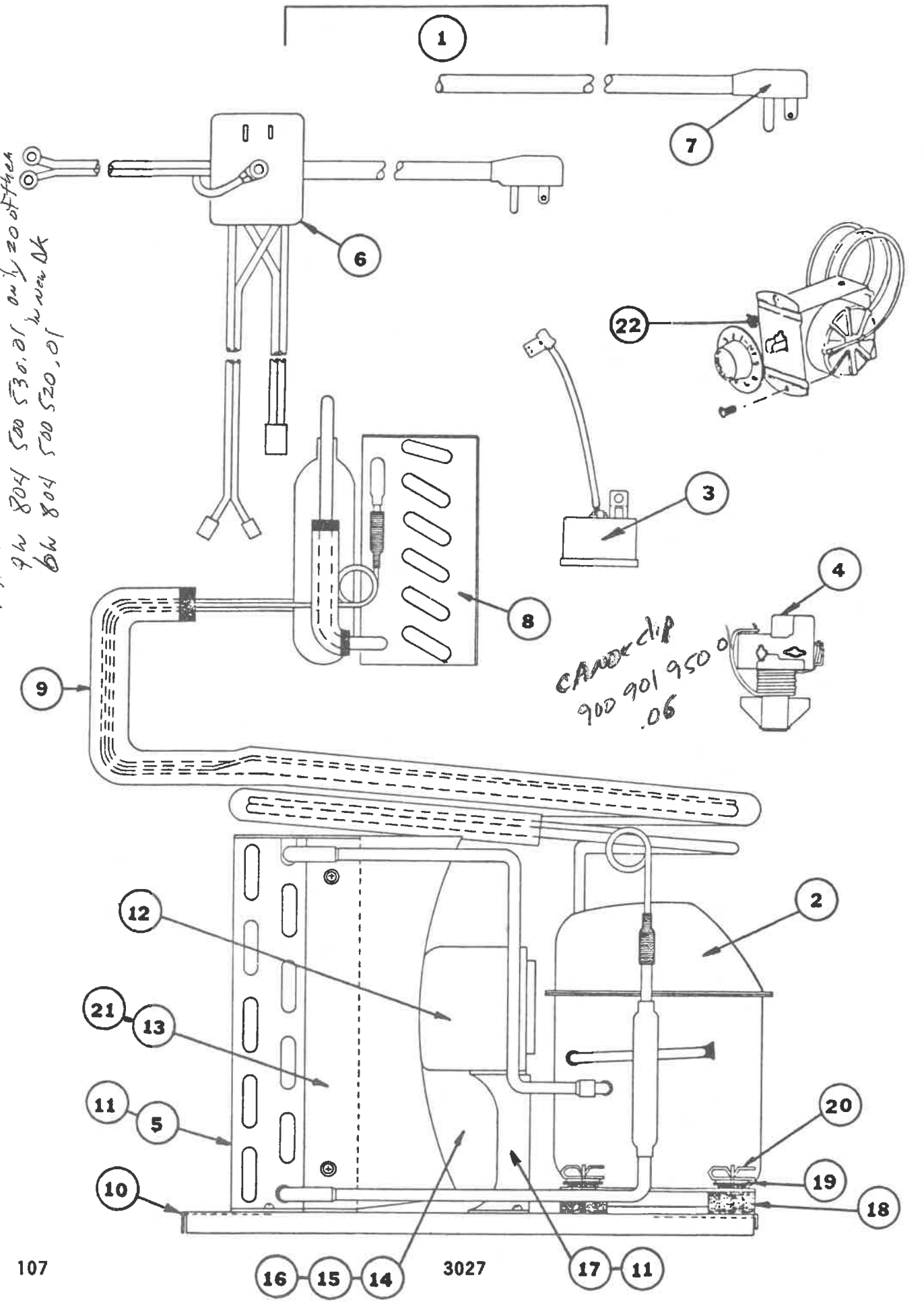

CAUTION  
900 901 950 0  
.06



REFRIGERATION SYSTEM

Item No.	PART NUMBER	PART NAME AND DESCRIPTION
DNCB 168/99-5 & -6, DNCB 240/138-5 & -6		
1	D142,040,002.43	Refrigeration System Complete, Model 400
2	802,500,110.01	Compressor, Model AE3430A Tecumseh
2	802,500,110.01	Compressor, 1/4 H.P. Americold
3	83458	Overload for AE3430A Compressor Tecumseh
*	(SPMRP-26 ALL-34)	Overload for AE3430A Compressor Tecumseh
3	1456-3163	Overload for 1/4 H.P. Americold
*	MST22ALK-319	Overload for 1/4 H.P. Americold
4a	82684	Relay for AE3430A Compressor Tecumseh
*	(SP9660-040-176)	Relay for AE3430A Compressor Tecumseh
4b	82483	Relay for AE3430A Compressor Tecumseh
*	(GE3ARR12-PB162)	Relay for AE3430A Compressor Tecumseh
4	1456-3164	Relay for 1/4 H.P. Americold
*	3CR-203-180	Relay for 1/4 H.P. Americold
5	C808,600,540.02	Condenser
DNCB 276/162-5 & 6    DNCB 330/189-5 & 6    DNCB 320/184-7 & 8    DNCB 368/216-7 & 8 DNCB 440/252-7 & 8    DNCB 304/174-9 & 10    DNCB 348/206-9 & 10    DNCB 414/239-9 & 10		
1	D143,040,402.13	Refrigeration System Complete, Model 300
2	802,500,170.01	Compressor, Model AE3440A Tecumseh
3	TEC8300MRTA78	Overload for AE3440A Compressor Tecumseh
*	(SPMRT-22AIN-34)	Overload for AE3440A Compressor Tecumseh
4a	TEC8209660A09	Relay for AE3440A Compressor Tecumseh
*	(SP9660-040-182)	Relay for AE3440A Compressor Tecumseh
4b	820RR12A10	Relay for AE3440A Compressor Tecumseh
*	(GE3ARR12-PB220)	Relay for AE3440A Compressor Tecumseh
5	D808,700,090.02	Condenser
DNCB 168/99-5 & 6    DNCB 240/138-5 & 6    DNCB 276/162-5 & 6    DNCB 330/189-5 & 6 DNCB 320/184-7 & 8    DNCB 360/210-5 & 6    DNCB 368/216-7 & 8    DNCB 432/246-5 & 6 DNCB 440/252-7 & 8    DNCB 304/174-9 & 10    DNCB 348/206-9 & 10    DNCB 414/239-9 & 10		
6	C804,900,601.51	Main Wiring Harness
7	A904,900,610.81	Compressor Lead w/plug
8	B802,600,870.51	Evaporator
9	903,300,530.01	Insulator Tube
10	C164,040,120.43	Base Plate - condensing unit
11	900,301,560.01	Screw Sems
12	802,302,120.02	Fan Motor - Cond.
13	D905,800,450.01	Shroud
14	900,103,370.02	Fan Blade
15	900,100,970.02-2	Silencer
16	900,100,970.02-1	Speed Nut
17	900,102,970.02	Fan Bracket
18	902,000,570.01	Grommet, compressor mounting
19	A901,803,910.11	Plug, compressor grommet
20	A900,901,880.01	Retainer Clip, compressor mounting
21	900,300,160.01	Screw, S/M #6 x 3/8
22	802,800,090.01	Temperature Control

\*Relative to Relays & Overloads, the numbers that appear in parenthesis ( ) are always stamped on the Relay & Overload. Either # can be used for ordering purposes. WHEN ORDERING PARTS, INDICATE MODEL # AND SERIAL # OF VENDER. ALL PRICES ARE SUBJECT TO CHANGE WITHOUT NOTICE.

MAIN DOOR ASSEMBLY – MAGNUM

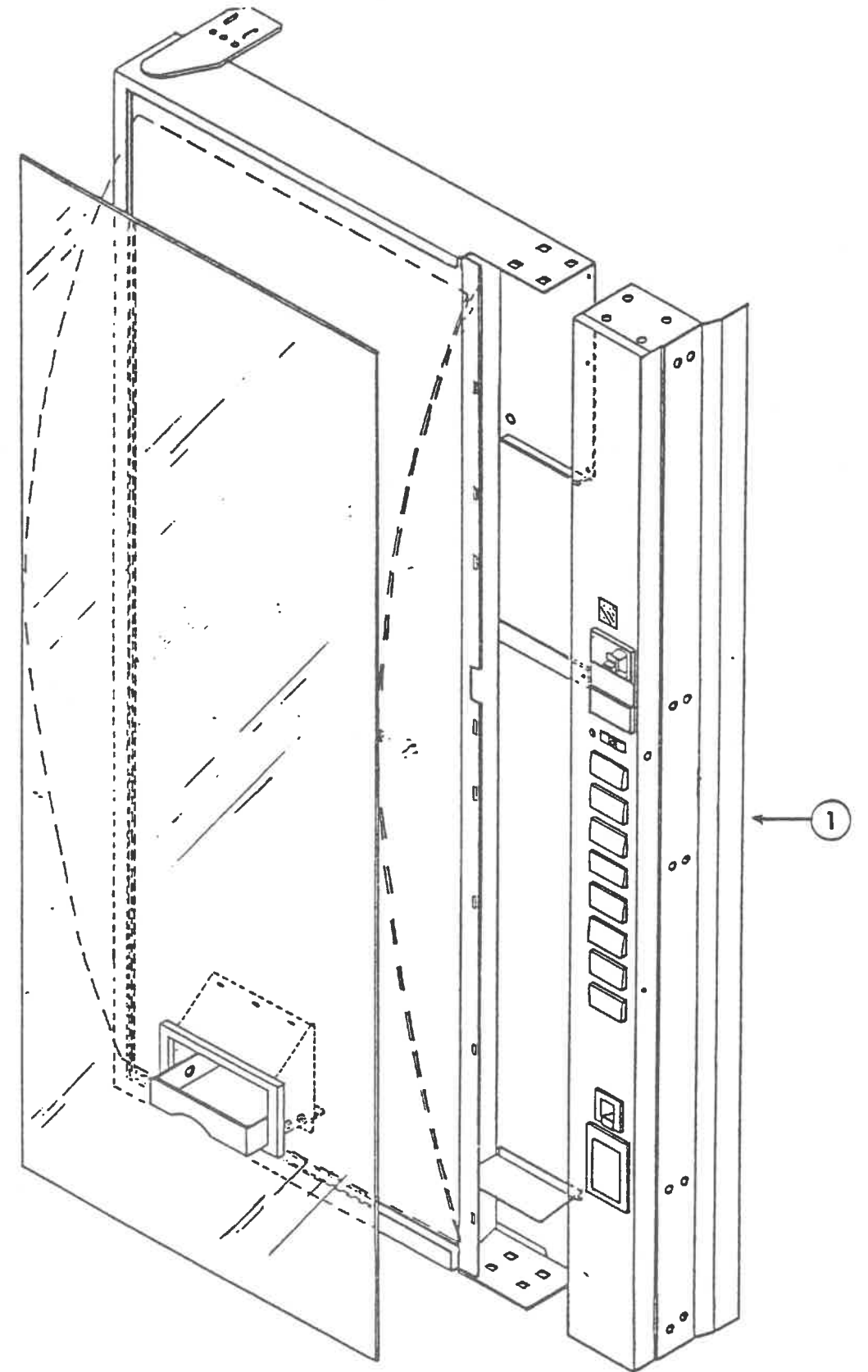

Parts List

MAIN DOOR ASSEMBLY – MAGNUM

Item No.	PART NUMBER	PART NAME AND DESCRIPTION
1A	360,050,000.03	Main Door Ass'y. — DNCB440M
1B	363,050,000.03	Main Door Ass'y. — DNCB368M
1C	368,050,000.03	Main Door Ass'y. — DNCB320M

WHEN ORDERING PARTS, INDICATE MODEL # AND SERIAL # OF VENDER.  
 ALL PRICES ARE SUBJECT TO CHANGE WITHOUT NOTICE.

MAIN DOOR WELDED ASSEMBLY – MAGNUM

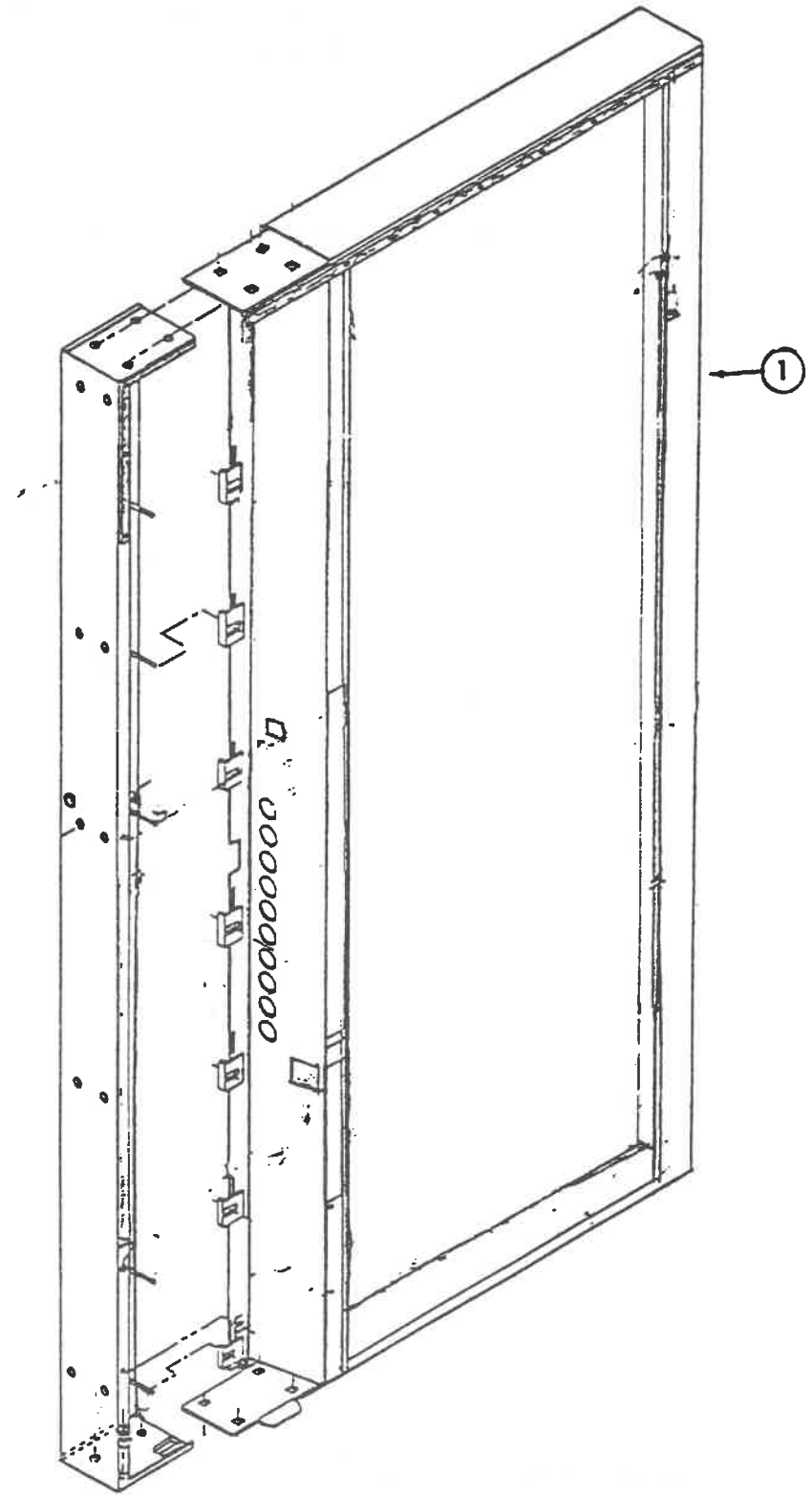

MAIN DOOR WELDED ASSEMBLY – MAGNUM

Item No.	PART NUMBER	PART NAME AND DESCRIPTION
1A	360,050,100.03	Main Door W/A – DNCB440M
1B	363,050,100.03	Main Door W/A – DNCB368M
1C	368,050,100.03	Main Door W/A – DNCB320M

WHEN ORDERING PARTS, INDICATE MODEL # AND SERIAL # OF VENDER.  
ALL PRICES ARE SUBJECT TO CHANGE WITHOUT NOTICE.

INNER DOOR ASSEMBLY – MAGNUM

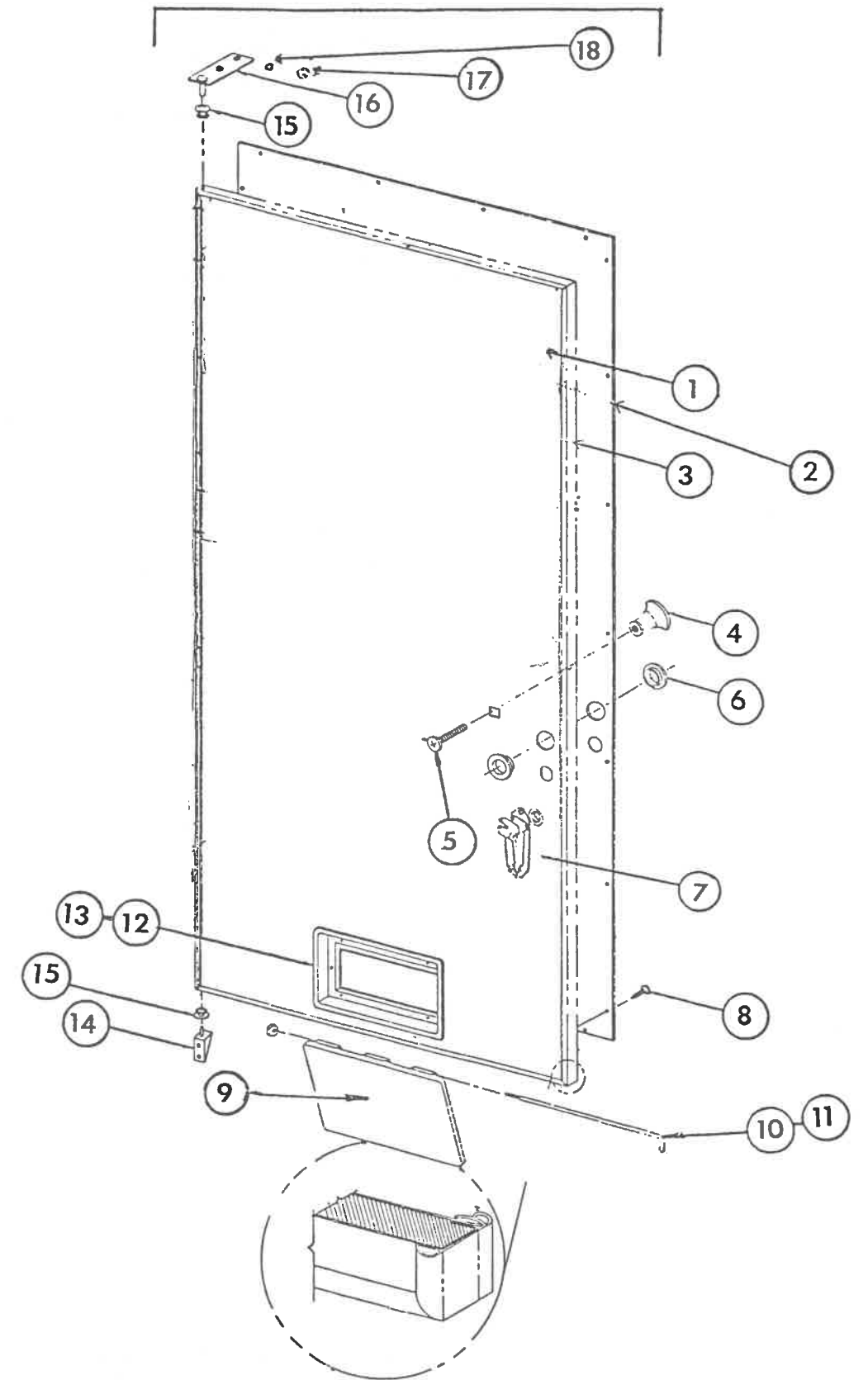

Parts List

INNER DOOR ASSEMBLY – MAGNUM

Item No.	PART NUMBER	PART NAME AND DESCRIPTION
1	Indicate Model # & Serial #	Inner Door Assembly
2	Indicate Model # & Serial #	Rear Panel, Replacement
3	Indicate Model # & Serial #	Gasket Inner Door
4	901,501,700.01	Knob
5	900,201,230.01	Carriage Bolt 1/4-20
6	901,901,360.01	Snap Bushing
7	A169,053,100.53	Burst Open Latch W/A
8	900,301,500.01	Screw, Self Drilling #8 x 1/2"
9	801,804,200.01	Delivery Door
10	A169,050,530.01	Hinge Pin
11	900,800,580.01	Lock Nut, Elastic
12	801,804,210.01	Frame Inner Door
13	901,100,460.01	Pop Rivet
14	A169,051,101.33	Inner Door Hinge, Bottom
15	901,803,710.01	Nyliner, Door Hinge
16	A169,053,001.03	Inner Door Hinge, Top
17	900,900,960.03	Nut 10-32, Top Hinge
18	903,000,170.01	Washer, Lock

WHEN ORDERING PARTS, INDICATE MODEL # AND SERIAL # OF VENDER.  
 ALL PRICES ARE SUBJECT TO CHANGE WITHOUT NOTICE.

CONTROL PANEL ASSEMBLY - MAGNUM

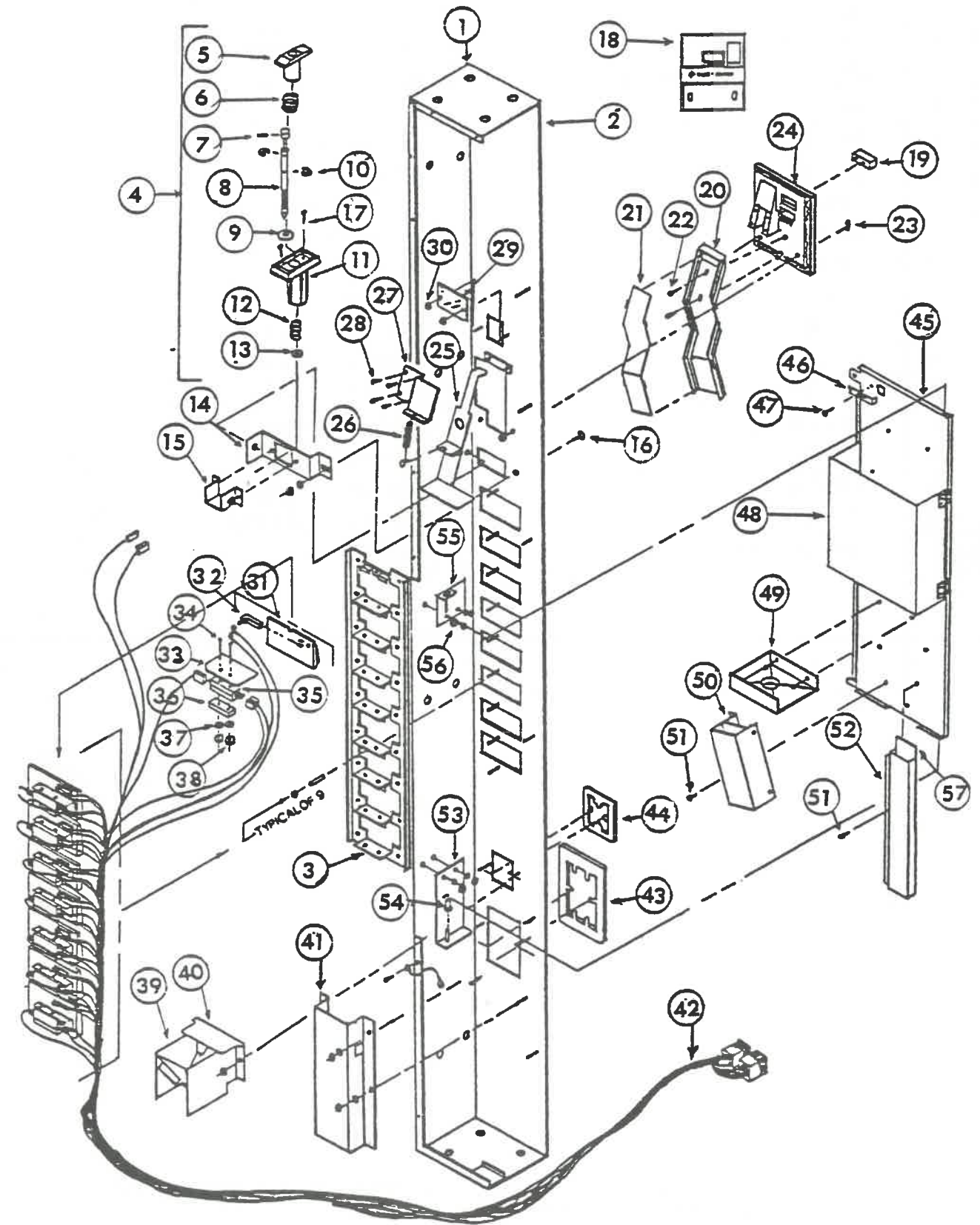



CONTROL PANEL ASSEMBLY - MAGNUM

Item No.	PART NUMBER	PART NAME AND DESCRIPTION
1	Indicate Model # & Serial #	Control Panel Ass'y. (Includes # 1-57)
2	Indicate Model # & Serial #	Control Panel Only
3	Indicate Model # & Serial #	Back Control Panel
4	801,502,100.01	T-Handle Ass'y. (Includes #5-13)
5		Handle Only
6	901,700,640.01	Spring
7	20-31	Pin
8	4255-6-56W	Stud
9	900,700,760.01	Washer
10	31-5	Clip
11		Body
12	901,700,640.01	Spring
13	900,700,760.01	Washer
14	B360,050,460.33	Handle Mount - Magnum
15	A360,050,530.03	T-Handle Shield
16	900,201,450.01	Carriage Bolt & Nut (1/4 -20 x 1/2")
17	900,901,510.02	Screw (#10 -32 x 5/8")
18	B/M360,010,500.04	Coin Insert Ass'y. (Includes # 18-28)
19	904,700,180.31	Lamp, Correct Change
20	D801,805,240.01	Coin Chute - Magnum
21	C801,805,250.01	Cover, Coin Chute - Magnum
22	900,301,700.01	Screw, Coin Chute (6 -32 x 3/8")
23	902,700,160.02	T-Bolt (8 -32 x 1/2")
24	D801,200,920.21	Coin Insert Only
25	B360,050,200.03	Coin Reject Arm W/A - Magnum
26	901,700,630.11	Spring, Coin Reject
27	A208,050,120.53	Plunger Retainer
28	900,301,700.03	Screw #6 -32 x 3/8"
29	C801,804,550.01	Price Window

WHEN ORDERING PARTS, INDICATE MODEL # AND SERIAL # OF VENDER.  
ALL PRICES ARE SUBJECT TO CHANGE WITHOUT NOTICE.

CONTROL PANEL ASSEMBLY - MAGNUM

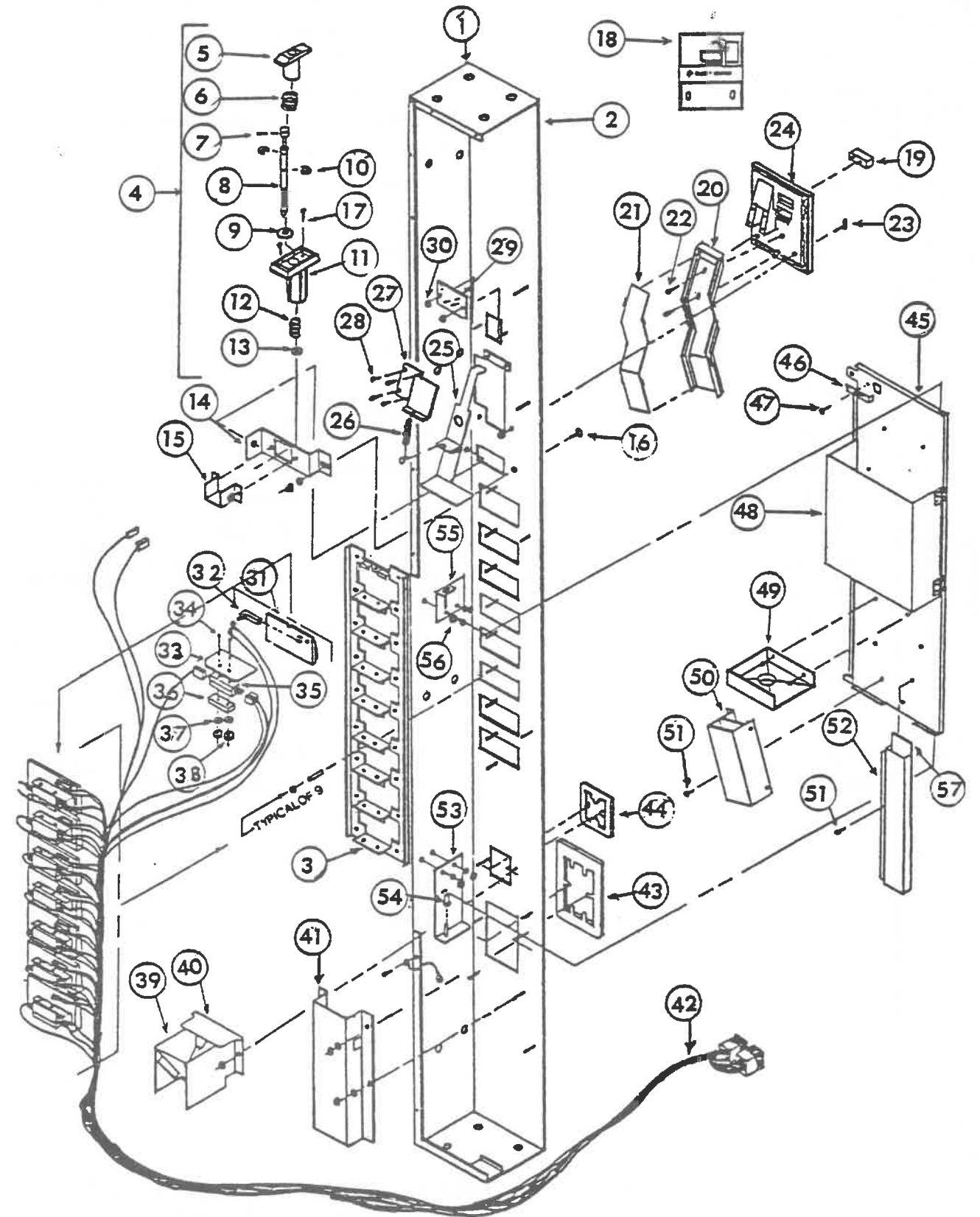

CONTROL PANEL ASSEMBLY - MAGNUM

Item No.	PART NUMBER	PART NAME AND DESCRIPTION
30	900,800,500.01	Keps Nut (#8 -32)
31	801,805,110.01	Select Button - Magnum
32	804,700,210.01	Lamp, Sold Out
33	801,804,620.01	Switch Shield & Spring
34	900,201,310.01	Screws Select Switch (6-32)
35	804,100,510.01	Select Switch
36	901,804,540.01	Spacer - Button Stop
37	(Not Needed)	Washer
38	900,800,490.01	Hex Nut - Keps
39	360,051,500.03	Coin Return Cup
40	267,050,610.0	Cover Change Cup
41	B360,050,570.13	Housing - Crown Puller
42	Indicate Model # & Serial #	Wiring Harness Control Panel
43	801,303,590.01	Bezel, Bottle Opener
44	801,303,600.01	Bezel, Coin Return
45	C360,050,290.63	Access Door
46	A360,050,440.03	Latch, Access Door
47	900,500,260.01	Screw Shoulder
48	B360,050,490.33	Changer Guard
49	801,804,300.01	Coin Hopper
50	C360,051,100.03	S/A Hopper Chute
51	900,301,560.01	Sems Screw (8 -32 x 3/8")
52	A360,050,270.13	Chute - Cash Box
53	B360,050,600.03	Bottom Hinge W/A (Access Door)
54	901,803,710.31	Bushing
55	B360,050,500.03	W/A Top Hinge - Access Door
56	900,700,390.01	Lock Washer
57	A360,050,260.03	Back - Chute Cash Box

WHEN ORDERING PARTS, INDICATE MODEL # AND SERIAL # OF VENDER.  
ALL PRICES ARE SUBJECT TO CHANGE WITHOUT NOTICE.

SIGN AND DELIVERY PORT AREA – MAGNUM

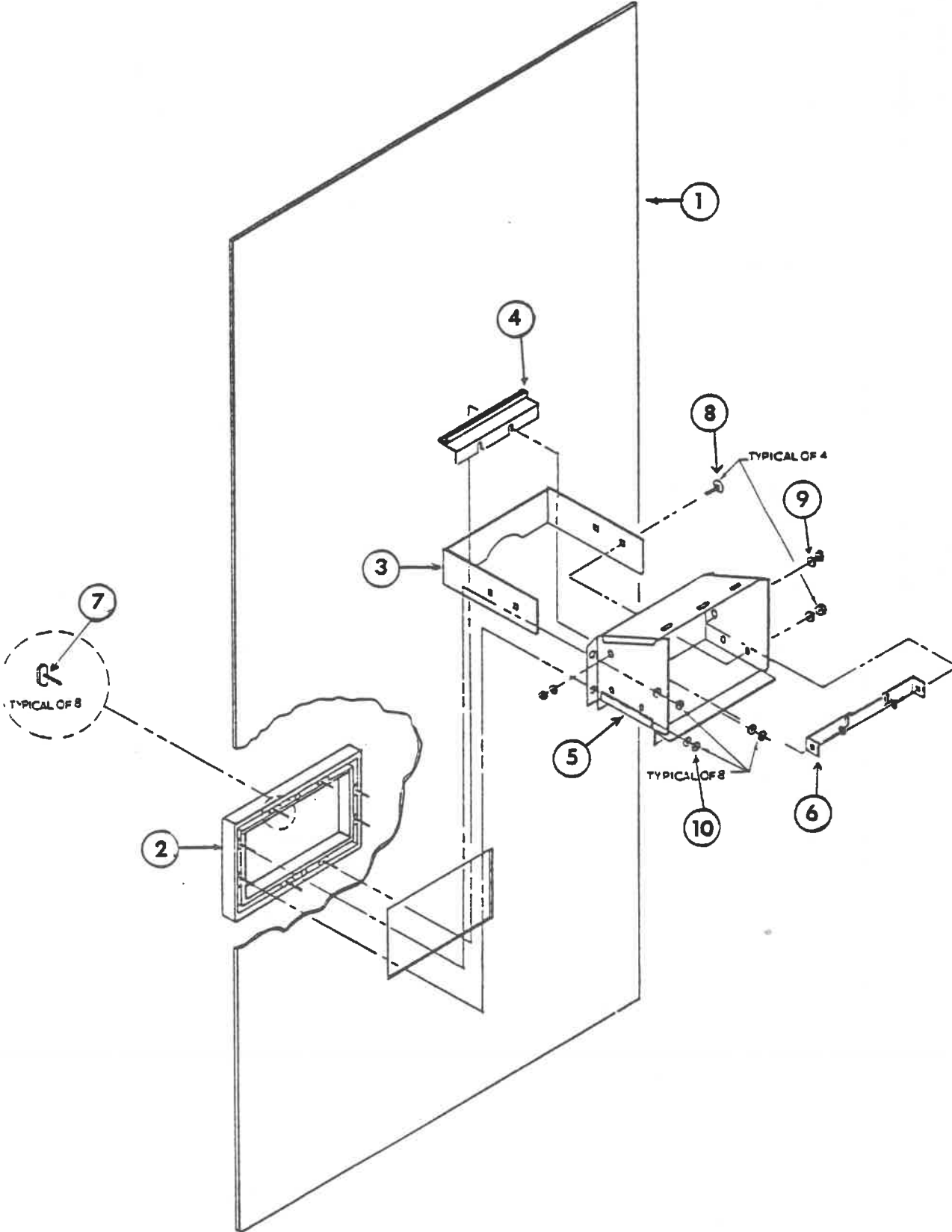

SIGN AND DELIVERY PORT AREA – MAGNUM

Item No.	PART NUMBER	PART NAME AND DESCRIPTION
1	Indicate Model # & Serial #	Sign - Magnum
2	801,602,510.11	Trim, Delivery Port
3	B360,050,370.23	Discharge Member - Magnum
4	A172,050,300.83	Bumper Ass'y.
5	C360,050,800.13	Delivery Chute Ass'y.
6	B360,050,380.31	Closure Strip
7	900,400,350.31	T-Bolt #8 x 3/4"
8	900,201,450.01	Carriage Bolt & Nut
9	900,700,390.01	Washer (1/4")
10	900,800,500.01	Keps Nut (8-32)

WHEN ORDERING PARTS, INDICATE MODEL # AND SERIAL # OF VENDER.  
ALL PRICES ARE SUBJECT TO CHANGE WITHOUT NOTICE.

PROTECTIVE PLATE AND INTERIOR MAIN DOOR PARTS – MAGNUM

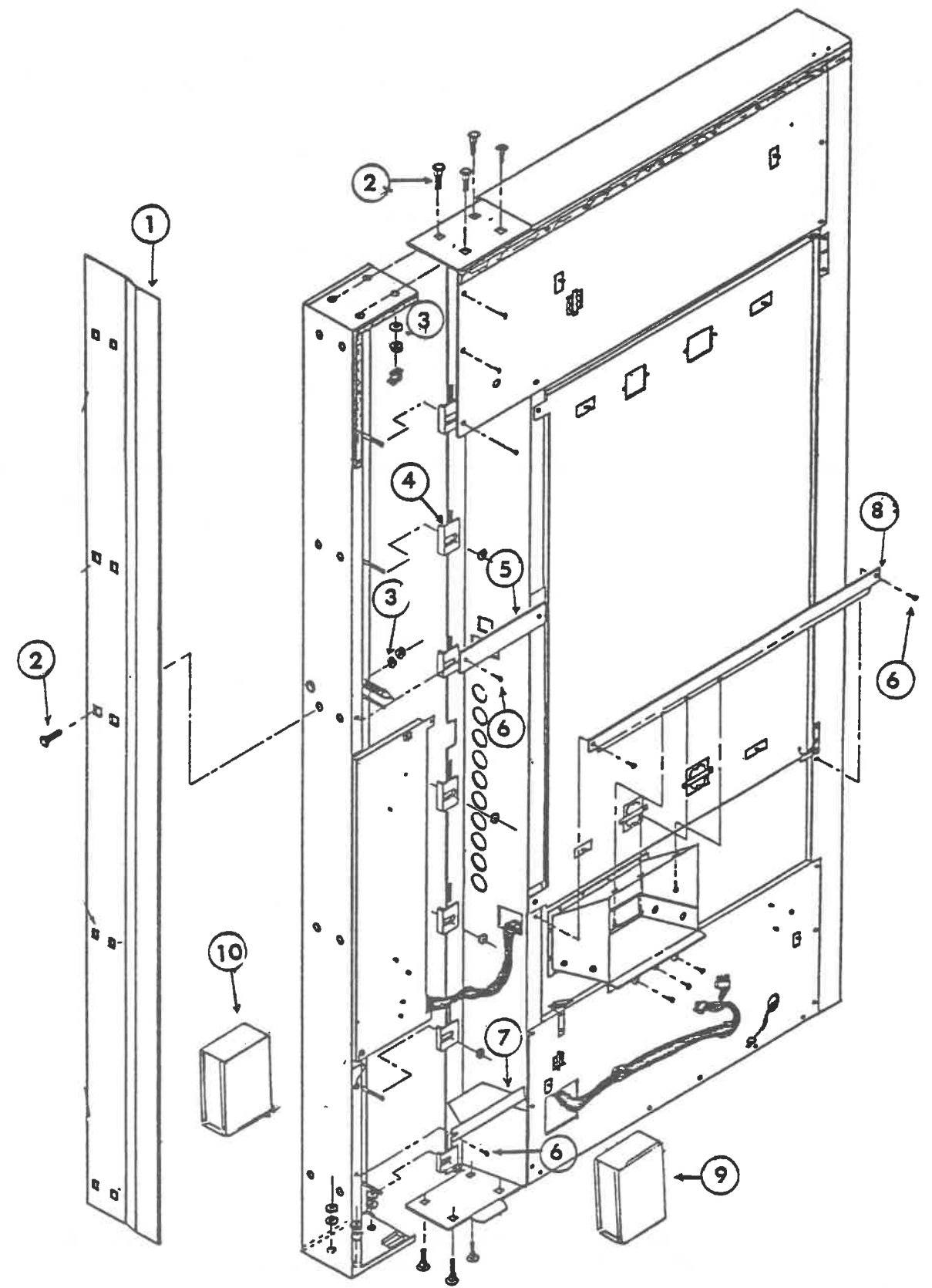

PROTECTIVE PLATE AND INTERIOR MAIN DOOR PARTS - MAGNUM

Item No.	PART NUMBER	PART NAME AND DESCRIPTION
1A	C164,150,330.03	Protective Plate Door - DNCB440M
1B	C165,150,330.03	Protective Plate Door - DNCB368M
1C	C166,150,330.03	Protective Plate Door - DNCB320M
2	900,201,450.01	Carriage Bolt and Nut (1/4-20)
3	900,700,390.01	Washer - Lock - 1/4"
4	A360,050,350.03	Bulkhead Clip
5	A360,050,580.03	Door Strap
6	900,301,500.01	Screw Self Drilling #8 x 1/2"
7	B360,050,390.01	Coin Box Shelf
8	B360,050,560.03	Door Stiffner
9	B360,050,700.03	Cash Box - Magnum
10	B360,051,600.03	Crown Catcher - Magnum

WHEN ORDERING PARTS, INDICATE MODEL # AND SERIAL # OF VENDER.  
 ALL PRICES ARE SUBJECT TO CHANGE WITHOUT NOTICE.

FLUORESCENT LAMPS FOR MAGNUM SERIALIZED 2752 AND HIGHER

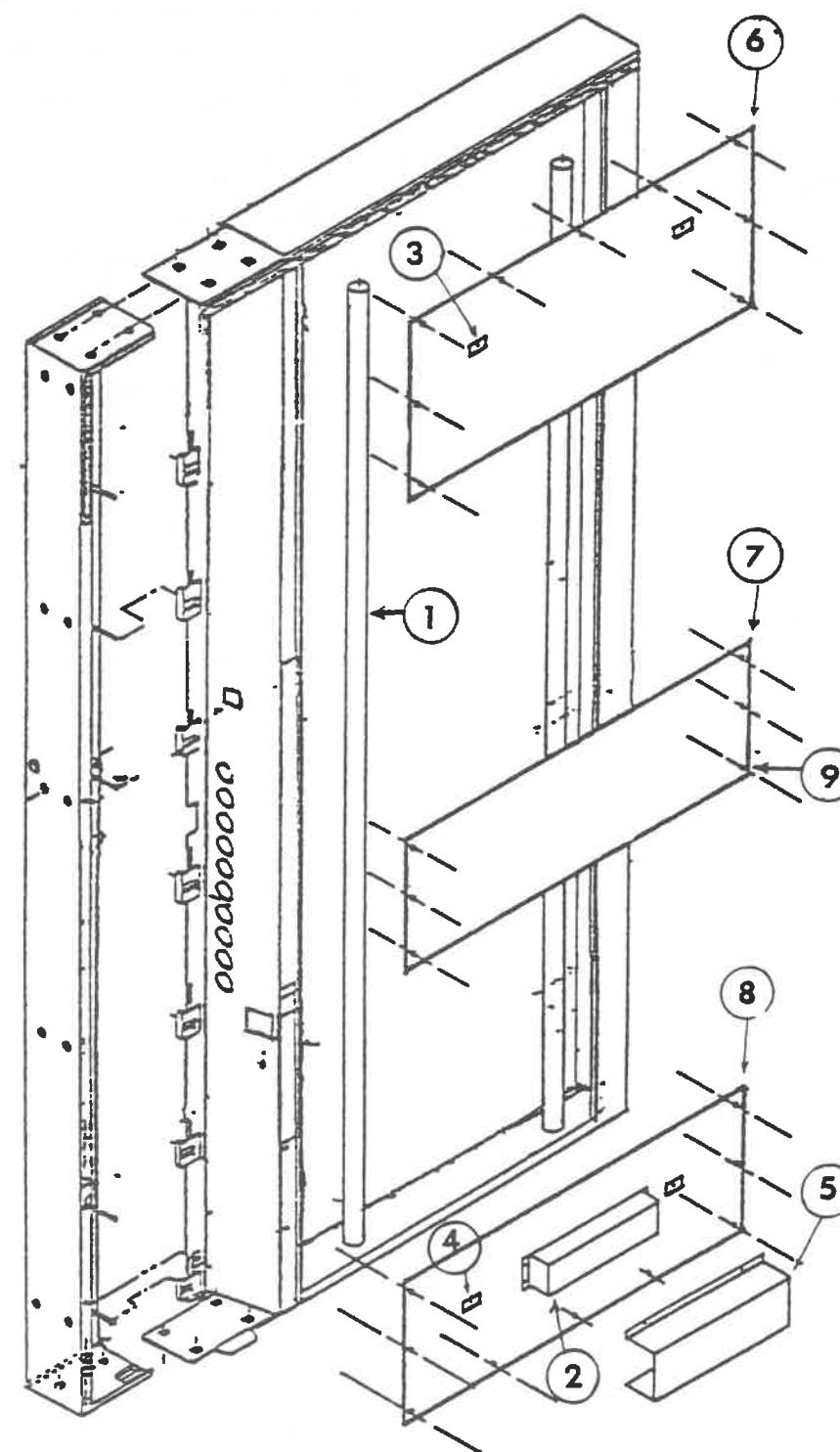



Parts List

FLUORESCENT LAMPS FOR MAGNUM SERIALIZED 2752 AND HIGHER

Item No.	PART NUMBER	PART NAME AND DESCRIPTION
1A	804,700,310.01	Fluorescent Bulb-72"-F72T12/D DNCB440M
1B	804,700,300.01	Fluorescent Bulb-64"-F64T12/D DNCB368M
1C	804,700,290.01	Fluorescent Bulb-60"-F60T12/D DNCB320M
2	804,400,210.01	Ballast SM-2E75-S-TP - All Magnum
3	804,901,910.01	Lamp Holder - top - All Magnum
4	804,901,920.01	Lamp Holder - bottom - All Magnum
5	B360,050,660.03	Cover Ballast - All Magnum
6	A360,050,630.03	Lamp Holder Bracket - top - All Magnum
7	360,050,650.03	Center Stiffner - All Magnum
8	A360,050,640.03	Lamp Holder Bracket - bottom - All Magnum
9	900,301,650.01	Self Drilling Screw (#8 x 1/2")

WHEN ORDERING PARTS, INDICATE MODEL # AND SERIAL # OF VENDER.  
 ALL PRICES ARE SUBJECT TO CHANGE WITHOUT NOTICE.

ASSEMBLY FOR MAGNUMS SERIALIZED 2679 THRU 2751

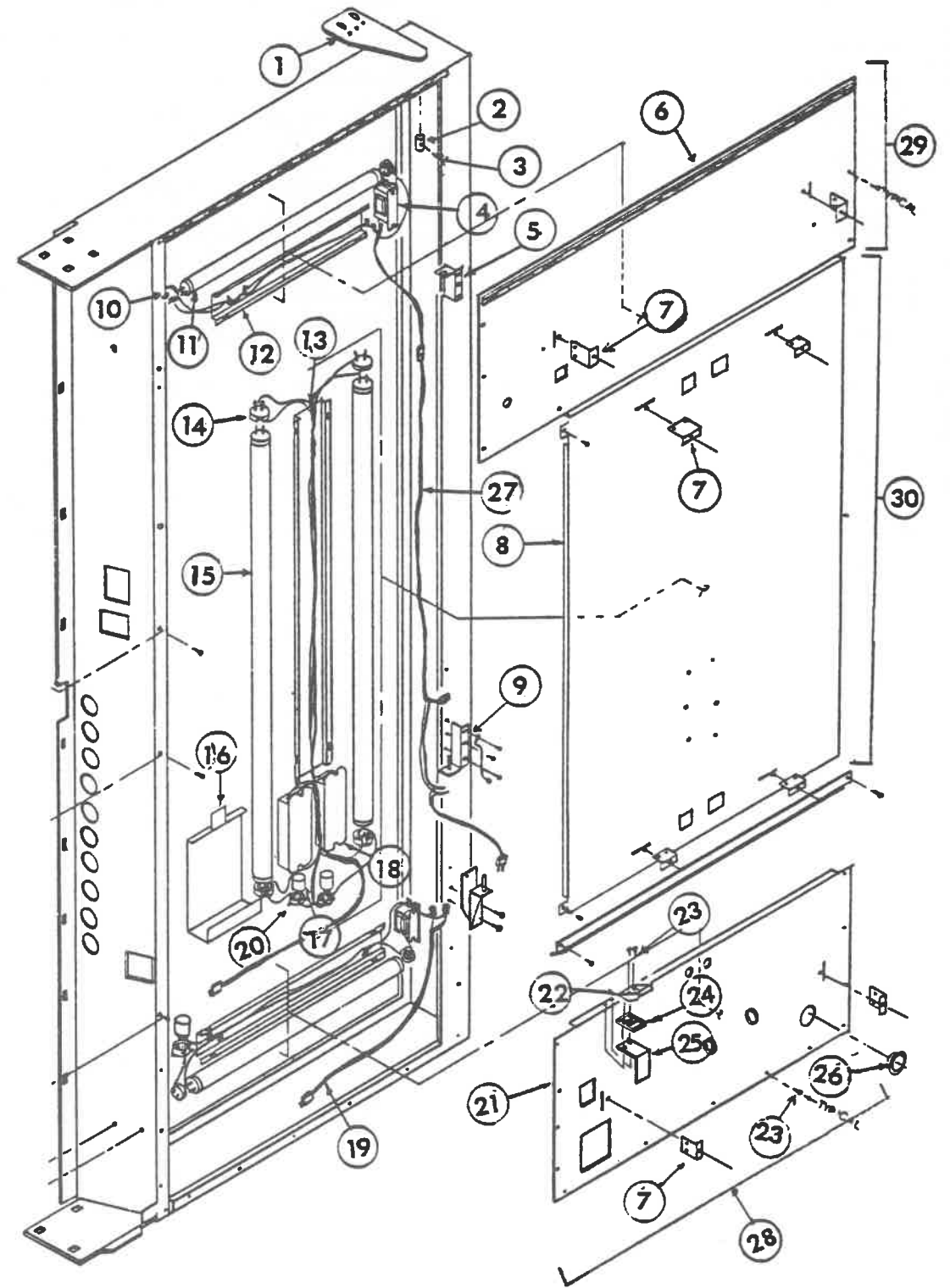

Parts List

ASSEMBLY FOR MAGNUMS SERIALIZED 2679 THRU 2751

Item No.	PART NUMBER	PART NAME AND DESCRIPTION
1	801,501,710.31	Top Main Door Hinge
2	800,502,030.01	Collar - Top Door Hinge
3	900,201,260.01	Lock Screw, Top Door Hinge
4	804,400,100.01	Ballast - Top & Bottom
5	A275,050,100.01	W/A Hinge - Top - Lamp Panel Door
6A	C360,050,160.03	Top Lamp Panel W/A - DNCB440M
6B	C363,050,070.43	Top Lamp Panel W/A - DNCB368M
6C	C376,050,020.23	Top Lamp Panel W/A - DNCB320M
7	A267,050,720.23	Bracket Lamp Socket
8A	D360,050,190.33	Lamp Panel Door W/A - Center DNCB440M & DNCB368M
8B	D368,050,060.33	Lamp Panel Door W/A - Center DNCB320
9	A267,051,500.03	W/A Hinge, Lamp Panel Door
10	904,901,230.01	Lamp Holder
11	804,700,050.01	Lamp 20 Watt - (24")
12	B360,050,180.03	Wire Cover
13	B270,050,070.01	Wire Cover - Lamp Door
14	804,700,150.01	Lamp - 25 Watt 33" - DNCB320
15	804,700,260.01	Lamp - 30 Watt 36" - DNCB440M & DNCB368M
16	C267,050,890.03	Ballast Cover
17	904,800,540.01	Starter FS-4 Lamp Door
18	804,400,140.01	Ballast - S40BP Lamp Door
19	A208,051,500.03	Lamp Panel Lead
20	904,900,710.01	Starter Socket - All Magnum
21	C360,050,170.53	Bottom Lamp Panel W/A - All Magnum
22	801,501,620.01	Strike - Latch
23	900,301,500.01	Self Drilling Screw #8 x 1/2"
24	801,501,630.01	Strike Plate - Latch
25	A360,050,310.23	Latch Roller - Bracket
26	901,901,360.01	Snap Bushing
27	B360,050,300.13	Jumper Lamp Panel
28	360,051,700.03	Bottom Lamp Panel Ass'y. - All Magnum
29A	360,051,900.03	Top Lamp Panel Ass'y. - DNCB440M
29B	363,050,500.03	Top Lamp Panel Ass'y. - DNCB368M & 320M
30A	360,051,800.03	Center Lamp Panel Door Ass'y. DNCB440M & DNCB368M
30B	368,050,400.03	Center Lamp Panel Door Ass'y. - DNCB320M

WHEN ORDERING PARTS, INDICATE MODEL # AND SERIAL # OF VENDER.  
ALL PRICES ARE SUBJECT TO CHANGE WITHOUT NOTICE.

MAIN DOOR ASSEMBLY - CENTURY II

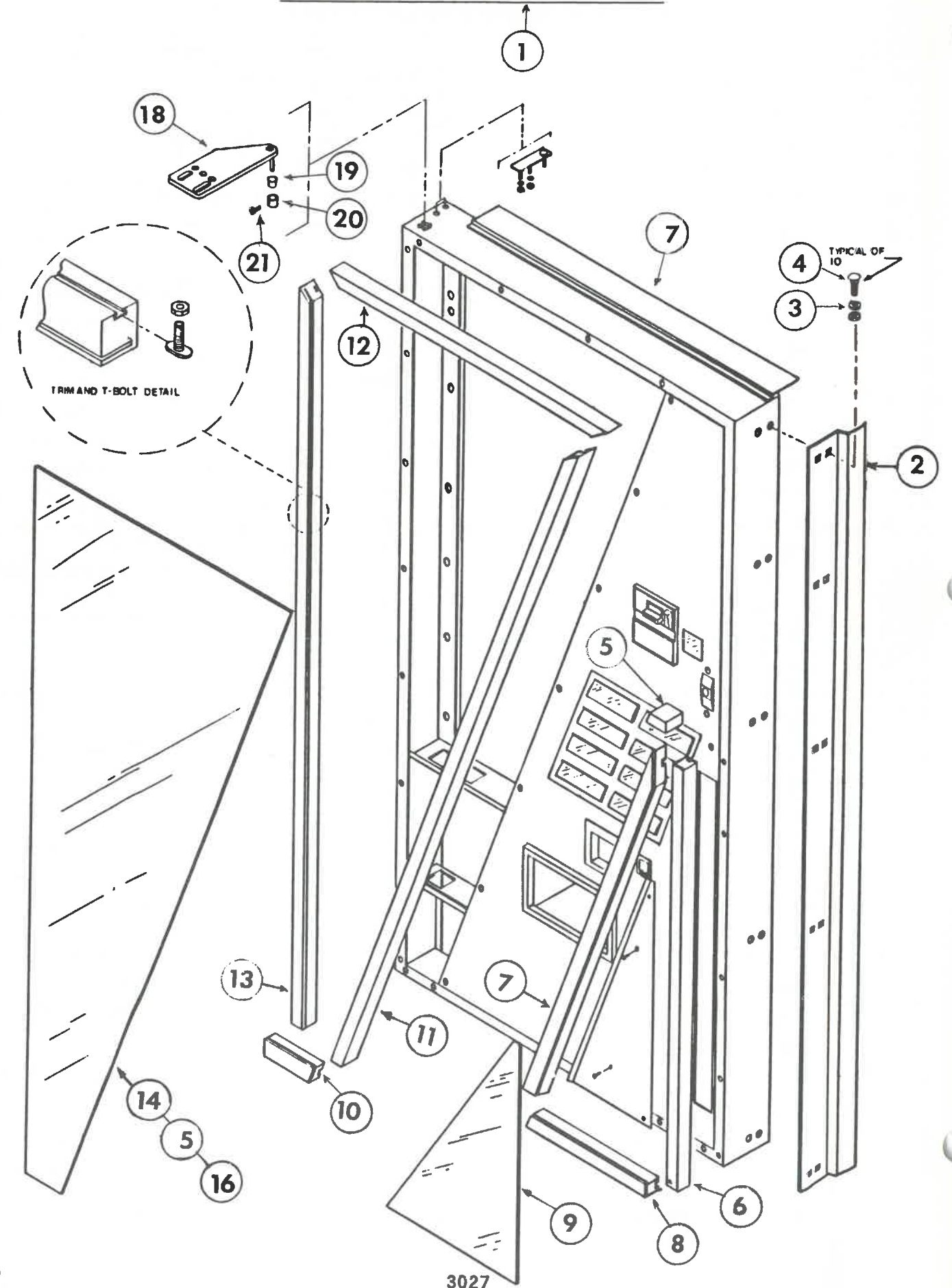



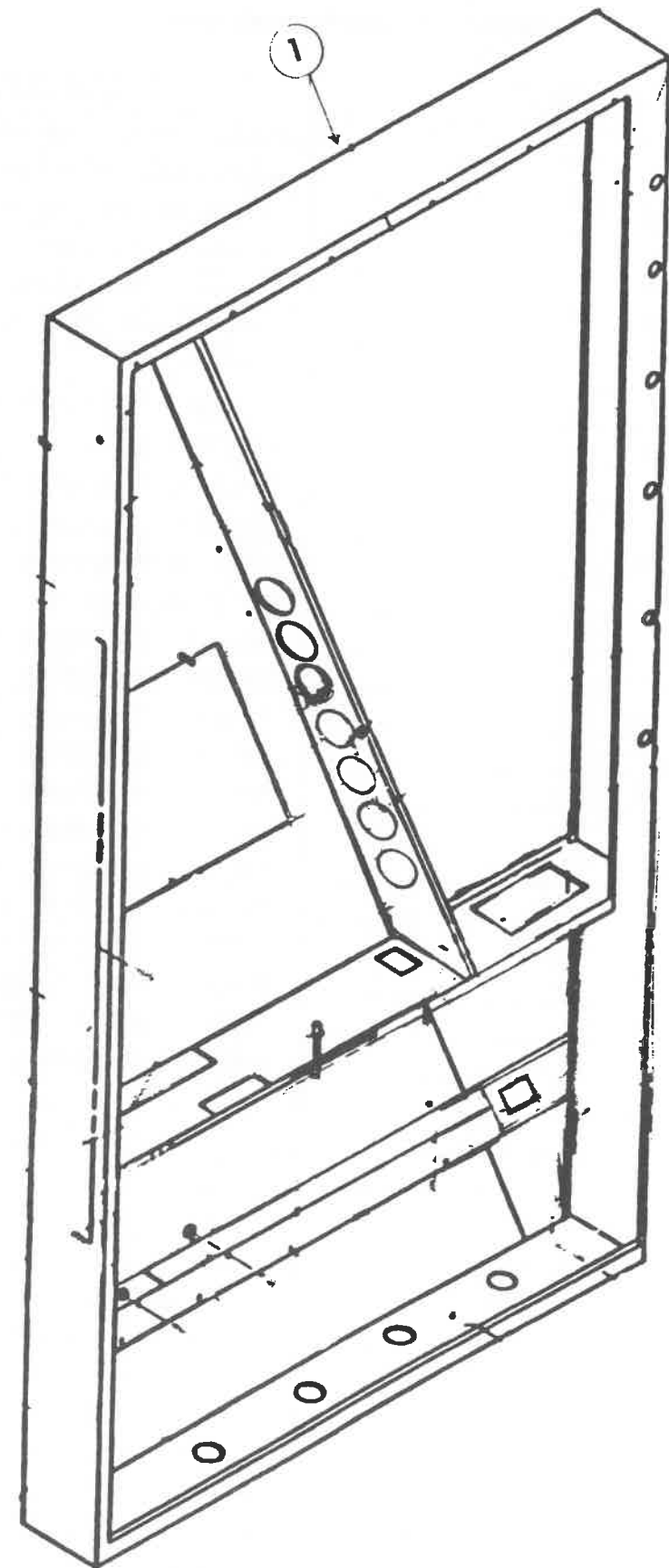

A = DNCB 440/252    DNCB 414/239  
B = DNCB 368/216    DNCB 348/206  
C = DNCB 320/184    DNCB 304/174

**MAIN DOOR W/A CENTURY II**

Item No.	PART NUMBER	PART NAME AND DESCRIPTION
1a	383,050,500.03	Main Door w/A
1b	384,050,100.03	Main Door w/A
1c	385,050,100.03	Main Door w/A

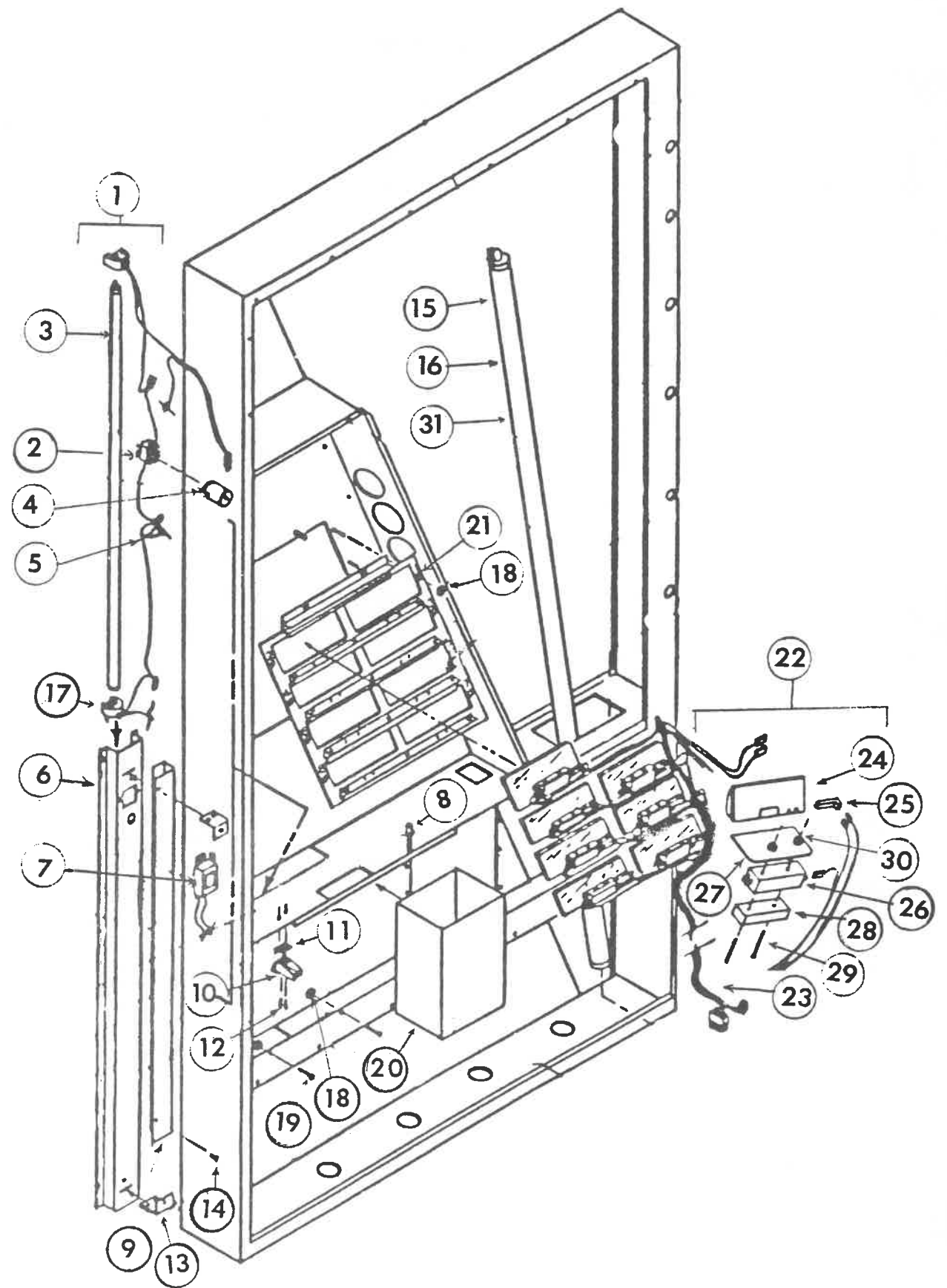





MAIN DOOR PARTS ACCESS AREA - CENTURY II

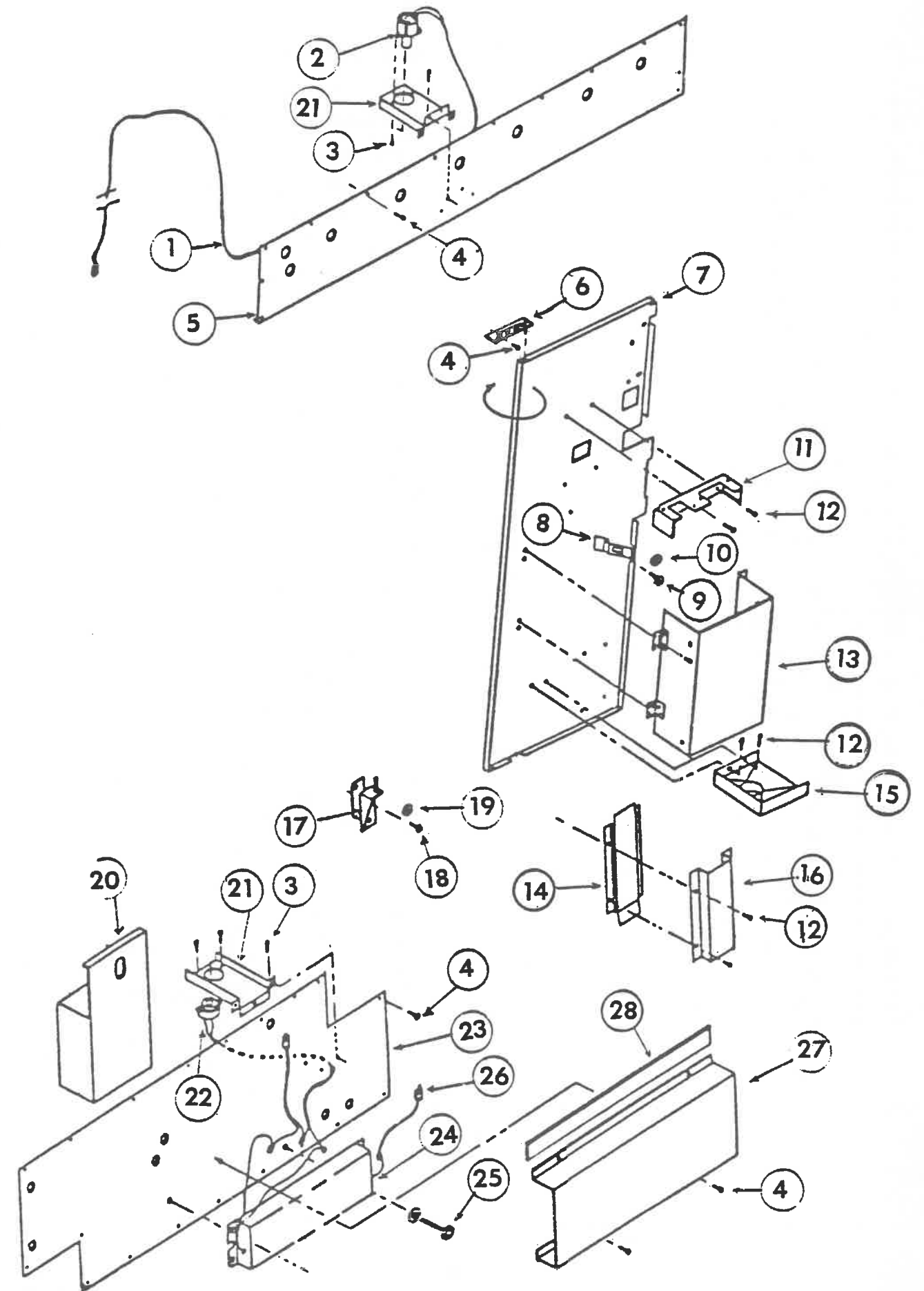



MAIN DOOR PARTS – ALL CENTURY II

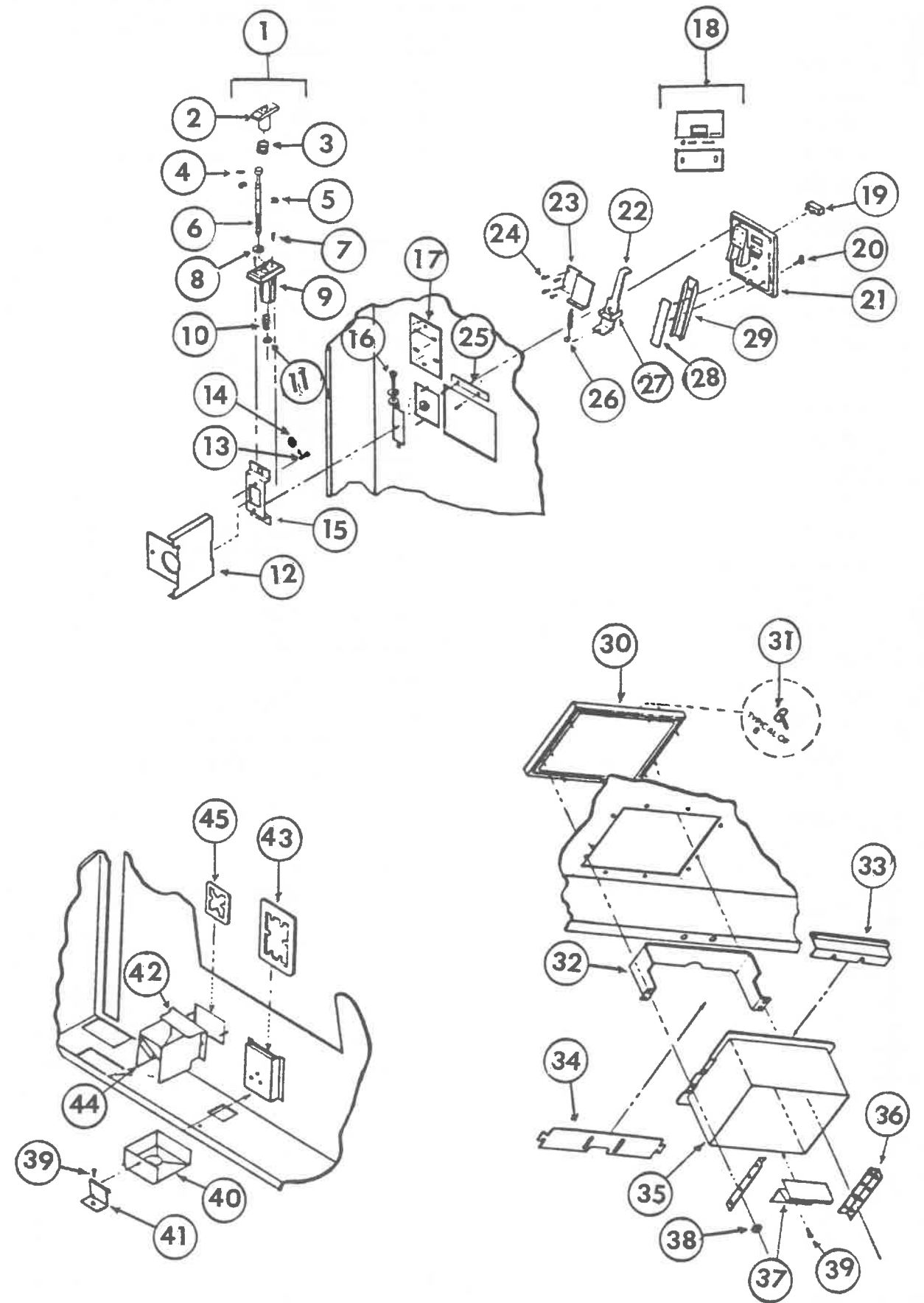

MAIN DOOR PARTS – ALL CENTURY II

Item No.	PART NUMBER	PART NAME AND DESCRIPTION
1	801,502,800.01	Tee Handle Ass'y. (# 1-11) (Black)
2		Handle (only)
3	900,700,760.01	Washer
4	20-31	Pin
5	31- 5	C-Clip
6	4255-6-56W	Stud
7	900,901,510.02	Screw
8		Washer-Hex.
9		Body (only)
10	901,700,640.01	Spring
11	900,700,760.01	Washer
12	B267,050,191.33	Brace Tee Handle
13	900,901,510.02	Machine Screw (# 10-32 x 5/8")
14	900,900,960.01	Hex Nut (# 10-32)
15	B267,050,480.13	Handle Mount
16	900,201,450.01	Carriage Bolt & Nut (1/4-20)
17	C801,804,550.01	Price Window
18	B/M 213,010,600.04	Coin Insert Ass'y. (Black) (# 18-29)
19	904,700,180.11	Lamp, Correct Change
20	902,700,160.01	T-Bolt (8-32 x 1/2")
21	801,201,110.01	Coin Insert (only) (Black)
22	801,303,610.51	Plunger, Coin Return
23	208,050,120.83	Plunger Retaining Plate
24	900,301,700.01	Screw (S/M #6)
25	A143,051,220.73	Retainer Coin Insert
26	901,700,630.11	Spring, Coin Reject
27	801,805,270.01	Drip Chute
28	801,805,380.01	Cover, Coin Chute
29	801,805,370.11	Coin Chute
30	801,602,510.11	Trim Del. Port
31	900,400,350.31	T-Bolt (# 8-32 x 3/4")
32	B231,050,300.03	Discharge Member
33	A172,050,300.73	Bumper Ass'y.
34	B172,050,031.33	Closure Strip
35	801,804,220.01	Delivery Chute
36	B169,050,371.13	Reinforcement Strip
37	383,050,390.03	Port Retainer
38	900,800,500.01	Keps Nut (# 8-32)
39	900,301,500.01	Screws # 8 Self Drilling
40	801,804,300.01	Hopper, Crown Puller
41	A176,150,330.13	Support - Hopper
42	A267,050,610.13	Cover - Change Cup
43	801,303,660.01	Bezel (Coin Return Black)
44	C267,052,000.03	Coin Return Cup
45	801,303,650.01	Bezel, (Opener Black)

DIXIE-NARCO